



w.styler

TEST SIEVES, SIEVE SHAKERS & PARTICLE ANALYSIS EQUIPMENT



ADDRESS

W.S. Tyler
8570 Tyler Boulevard,
Mentor, OH 44060, USA
www.wstyler.com



PHONE

1-800-321-6188
1-440-974-1047



A Haver & Boecker Company

RC-TAP

TABLE OF CONTENT

OUR STORY	3
W.S. TYLER TEST SIEVES	4
8" DIAMETER TEST SIEVES	7
12" DIAMETER TEST SIEVES	11
3" DIAMETER TEST SIEVES	15
200MM DIAMETER TEST SIEVES	18
300MM DIAMETER TEST SIEVES	21
NON-STANDARD TEST SIEVES	24
WET WASH TEST SIEVE	31
CERTIFICATION AND TESTING SERVICES	33
W.S. TYLER RO-TAP®	39
W.S. TYLER CPA	56
ALPINE AIR JET	59

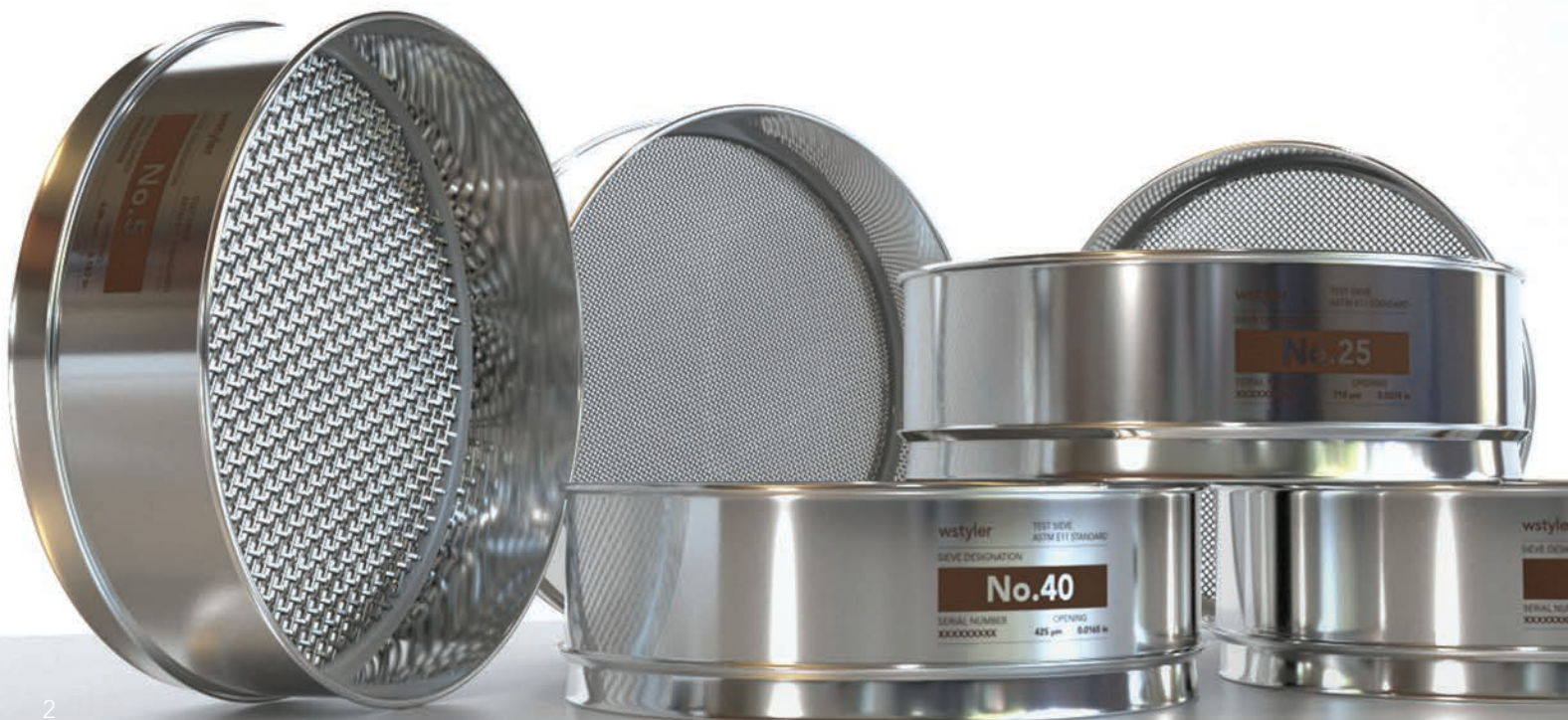

OUR STORY

Founded in 1872, W.S. Tyler quickly established itself as a pioneer in the engineering and production of woven wire and mesh materials. For over 140 years, we have been committed to maintaining that standard of excellence. Today, W.S. Tyler is partnered with German multinational Haver & Boecker, solidifying our place as one of the world's leading manufacturers of wire cloth and mesh materials.

Our combination of innovation and tradition allows us to meet and exceed the high expectations of our customers. With a wealth of experience, relentless research and development, and a passion for precision, W.S. Tyler remains well-positioned to continue its vision into the future.

Our particle analysis division is a product of that vision.

Precision is an essential component in most industrial manufacturing and machining processes. In these cases, a careful analysis of materials and substances is critical to

achieving the best results. Based on our extensive expertise and experience, W.S. Tyler protects your investment and provides innovative systems for particle analysis. Whether it's natural minerals, construction materials, foodstuffs, recyclables, chemicals, plastics, or varnishes, paints, and special coatings, our systems deliver accurate analysis and improved quality assurance.

W.S. Tyler is certified in accordance with ISO 9001:2015 and, as the world's largest manufacturer of test sieves, is a member of the ASTM E11 Standard Committee. Given our position as a pioneer, our customers in various industries and research and development divisions have the confidence and peace of mind that our test sieves – like all of our products – are manufactured to meet the most stringent technical requirements, from the choice of wire grade to the performance of the finished products. With our combined suite of services, W.S. Tyler is an efficient, full-service partner for all of your particle analysis needs.

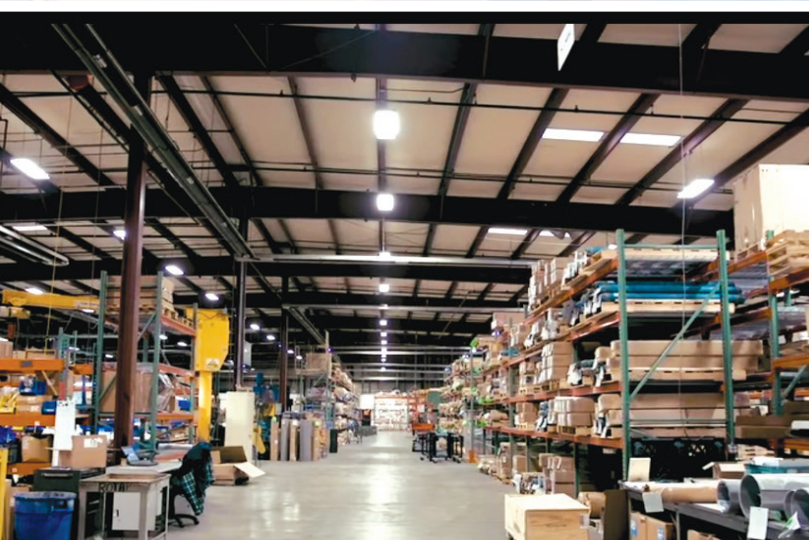

W.S. TYLER TEST SIEVES

W.S. Tyler developed the basis for the first Test Sieve standard over 100 years ago. Repeatable test results and particle size distribution curves from laboratory to laboratory are extremely important to quality control programs.

Our test sieve cloth and test sieves are manufactured in accordance with all applicable standards and monitored by our robust Quality Management System. Unless otherwise agreed, we supply all test sieves with a free Certificate of Compliance.

W.S. Tyler provides Test Sieves in three grades:

- Standard: Supplied with a Certificate of Compliance. Equal to ASTM E11 Compliance Sieve.
- Certified: Supplied with NIST traceable histogram. Equal to ASTM E11 Inspection Sieve. See Sieve Analysis and Calibration for more information.
- Certified-PLUS: Supplied with NIST traceable histogram. Equal to ASTM E11 Calibration Sieve. See Sieve Analysis and Calibration for more information on page 35.



INFORMATION/GUIDE FOR TEST SIEVING

For information regarding specific specifications, please refer to Standards ASTM E11 & ISO 565, 3310-1

Standard *A	Sieve Designation Alternative *D	Nominal Sieve Opening (in.) *B	Permissible Variations in Average Openings	Maximum Individual Openings	Permissible Average Wire Diameter (mm) *C	
					Minimum	Maximum
125 mm	5 in.	5.00	± 3.30 mm	129.06 mm	6.8	9.2
112 mm		4.41	± 2.96 mm	115.74 mm	6.8	9.2
106 mm	4.24 in.	4.24	± 2.80 mm	109.59 mm	5.4	7.2
100 mm	4 in.	4.00	± 2.65 mm	103.44 mm	5.4	7.2
90 mm	3-1/2 in.	3.50	± 2.39 mm	93.18 mm	5.4	7.2
80 mm		3.15	± 2.13 mm	82.91 mm	5.4	7.2
75 mm	3 in.	3.00	± 2.00 mm	77.78 mm	5.4	7.2
71 mm		2.80	± 1.89 mm	73.67 mm	4.8	6.4
63 mm	2-1/2 in.	2.50	± 1.69 mm	65.44 mm	4.8	6.4
56 mm		2.20	± 1.50 mm	58.24 mm	4.3	5.8
53 mm	2.12 in.	2.12	± 1.42 mm	55.15 mm	4.3	5.8
50 mm	2 in.	2.00	± 1.34 mm	52.06 mm	4.3	5.8
45 mm	1-3/4 in.	1.75	± 1.21 mm	46.91 mm	3.8	5.2
40 mm		1.57	± 1.08 mm	41.45 mm	3.8	5.2
37.5 mm	1-1/2 in.	1.50	± 1.01 mm	39.17 mm	3.8	5.2
35.5 mm		1.40	± 0.961 mm	37.10 mm	3.4	4.6
31.5 mm	1-1/4 in.	1.25	± 0.855 mm	32.97 mm	3.4	4.6
28 mm		1.10	± 0.762 mm	29.35 mm	3.0	4.1
26.5 mm	1.06 in.	1.06	± 0.722 mm	27.79 mm	3.0	4.1
25 mm	1 in.	1.00	± 0.682 mm	26.24 mm	3.0	4.1
22.4 mm	7/8 in.	.875	± 0.613 mm	23.54 mm	3.0	4.1
20 mm		.787	± 0.548 mm	21.05 mm	2.7	3.6
19 mm	3/4 in.	.750	± 0.522 mm	20.01 mm	2.7	3.6
18 mm		.709	± 0.495 mm	18.97 mm	2.7	3.6
16 mm	5/8 in.	.625	± 0.441 mm	16.89 mm	2.7	3.6
14 mm		.551	± 0.387 mm	14.81 mm	2.4	3.2
13.2 mm	.530 in.	.530	± 0.365 mm	13.98 mm	2.4	3.2
12.5 mm	1/2 in.	.500	± 0.346 mm	13.25 mm	2.1	2.9
11.2 mm	7/16 in.	.438	± 0.311 mm	11.89 mm	2.1	2.9
10 mm		.394	± 0.279 mm	10.64 mm	2.1	2.9
9.5 mm	3/8 in.	.375	± 0.265 mm	10.11 mm	1.9	2.6
9 mm		.354	± 0.251 mm	9.59 mm	1.9	2.6
8 mm	5/16 in.	.312	± 0.224 mm	8.54 mm	1.7	2.3
7.1 mm		.280	± 0.20 mm	7.60 mm	1.5	2.1
6.7 mm	.265 in.	.265	± 0.189 mm	7.18 mm	1.5	2.1
6.3 mm	1/4 in.	.250	± 0.178 mm	6.76 mm	1.5	2.1
5.6 mm	No. 3-1/2 *D	.223	± 0.159 mm	6.02 mm	1.3	1.9
5 mm		.197	± 0.142 mm	5.39 mm	1.3	1.9
4.75 mm	No. 4	.187	± 0.135 mm	5.12 mm	1.3	1.9
4.5 mm		.177	± 0.128 mm	4.86 mm	1.2	1.7
4 mm	No. 5	.157	± 0.114 mm	4.33 mm	1.2	1.7
3.55 mm		.140	± 0.102 mm	3.85 mm	1.06	1.5
3.35 mm	No. 6	.132	± 0.096 mm	3.64 mm	1.06	1.5
3.15 mm		.124	± 0.091 mm	3.43 mm	1.06	1.5
2.8 mm	No. 7	.110	± 0.081 mm	3.06 mm	.95	1.3
2.5 mm		.0984	± 0.073 mm	2.74 mm	.85	1.15
2.36 mm	No. 8	.0937	± 0.069 mm	2.59 mm	.85	1.15
2.24 mm		.0882	± 0.065 mm	2.46 mm	.77	1.04
2 mm	No. 10	.0787	± 0.059 mm	2.20 mm	.77	1.04
1.8 mm		.0709	± 0.053 mm	1.99 mm	.68	.92
1.7 mm	No. 12	.0661	± 0.050 mm	1.88 mm	.68	.92
1.6 mm		.0630	± 0.047 mm	1.77 mm	.68	.92
1.4 mm	No. 14	.0555	± 0.042 mm	1.56 mm	.60	.82
1.25 mm		.0492	± 0.038 mm	1.40 mm	.54	.72

INFORMATION/GUIDE FOR TEST SIEVING

For information regarding specific specifications, please refer to Standards ASTM E11 & ISO 565, 3310-1

Standard *A	Sieve Designation Alternative *D	Nominal Sieve (in.) *B	Permissible Variations in Average Openings	Maximum Individual Openings	Permissible Average Wire Diameter *C	
					Minimum	Maximum
1.18 mm	No. 16	.0469	± 0.036 mm	1.32 mm	.54	.72
1.12 mm		.0411	± 0.034 mm	1.26 mm	.48	.64
1 mm	No. 18	.0394	± 0.03 mm	1.13 mm	.48	.64
900 µm *E		.0354	± 27.60 µm	1018 µm	.43	.58
850 µm	No. 20	.0331	± 26.20 µm	964 µm	.43	.58
800 µm		.0315	± 24.80 µm	909 µm	.38	.52
710 µm	No. 25	.0278	± 22.20 µm	811 µm	.38	.52
630 µm		.0248	± 19.90 µm	723 µm	.34	.46
600 µm	No. 30	.0234	± 19.00 µm	691 µm	.34	.46
560 µm		.0220	± 17.90 µm	647 µm	.30	.41
500 µm	No. 35	.0197	± 16.20 µm	580 µm	.27	.36
450 µm		.0177	± 14.70 µm	525 µm	.24	.32
425 µm	No. 40	.0165	± 14.00 µm	498 µm	.24	.32
400 µm		.0157	± 13.30 µm	470 µm	.21	.29
355 µm	No. 45	.0139	± 12.00 µm	420 µm	.19	.26
315 µm		.0124	± 10.80 µm	375 µm	.17	.23
300 µm	No. 50	.0117	± 10.40 µm	358 µm	.17	.23
280 µm		.0110	± 9.80 µm	336 µm	.15	.21
250 µm	No. 60	.0098	± 8.90 µm	302 µm	.13	.19
224 µm		.0088	± 8.10 µm	273 µm	.13	.19
212 µm	No. 70	.0083	± 7.80 µm	259 µm	.12	.17
200 µm		.0079	± 7.40 µm	245 µm	.12	.17
180 µm	No. 80	.0070	± 6.80 µm	223 µm	.106	.15
160 µm		.0063	± 6.30 µm	200 µm	.095	.13
150 µm	No. 100	.0059	± 6.00 µm	188 µm	.085	.115
140 µm		.0055	± 5.70 µm	177 µm	.085	.115
125 µm	No. 120	.0049	± 5.20 µm	159 µm	.077	.104
112 µm		.0044	± 4.80 µm	144 µm	.068	.092
106 µm	No. 140	.0041	± 4.70 µm	137 µm	.06	.082
100 µm		.0039	± 4.50 µm	130 µm	.06	.082
90 µm	No. 170	.0035	± 4.20 µm	119 µm	.054	.072
80 µm		.0031	± 3.90 µm	107 µm	.048	.064
75 µm	No. 200	.0029	± 3.70 µm	101 µm	.043	.058
71 µm		.0028	± 3.60 µm	96 µm	.043	.058
63 µm	No. 230	.0025	± 3.40 µm	87 µm	.038	.052
56 µm		.0022	± 3.20 µm	78 µm	.034	.046
53 µm	No. 270	.0021	± 3.10 µm	74 µm	.031	.041
50 µm		.0020	± 3.00 µm	71 µm	.031	.041
45 µm	No. 325	.0017	± 2.80 µm	65 µm	.027	.037
40 µm		.0016	± 2.70 µm	59 µm	.027	.037
38 µm	No. 400	.0015	± 2.60 µm	56 µm	.024	.035
36 µm		.0014	± 2.60 µm	54 µm	.024	.035
32 µm	No. 450	.0012	± 2.40 µm	49 µm	.023	.033
25 µm	No. 500	.0010	± 2.20 µm	40 µm	.021	.029
20 µm	No. 635	.0008	± 2.10 µm	33 µm	.017	.023

*A	These Standard Designations correspond to the values for the test sieve openings recommended by the International Standards Organization, Geneva, Switzerland. Except where noted
*B	Only approximately equivalent to the metric values in column 1
*C	The average diameter of the wires in the x and y direction, measured separately, of any wire cloth shall not deviate from the nominal values by more than +/- 15%
*D	These numbers (3-1/2 to 635 are approximate number of openings per linear in. but it is preferred that the sieve be identified by the standard designation in millimeters or micrometers
*E	1000 µm – 1 mm

8" DIAMETER TEST SIEVES



8" DIAMETER TEST SIEVES

Designation		Stainless Frame- Stainless Cloth		Brass Frame- Stainless Cloth		Brass Frame- Brass Cloth	
USA	Supplementary	Full Ht. Part No.	Half Ht. Part No.	Full Ht. Part No.	Half Ht. Part No.	Full Ht. Part No.	Half Ht. Part No.
4 in.	100 mm	5167	5337	4835	5001	-	-
3-1/2 in.	90 mm	5168	5334	4836	5002	-	-
	80 mm	2442	-	2050	-	-	-
3 in.	75 mm	5169	5335	4837	5003	-	-
	71 mm	-	-	-	-	-	-
2-1/2 in.	63 mm	5170	5336	4838	5004	-	-
	56 mm	-	-	3191	-	-	-
2.12 in.	53 mm	5171	-	4839	-	-	-
2 in.	50 mm	5172	-	4840	-	-	-
1-3/4 in.	45 mm	5173	-	4841	-	-	-
	40 mm	3526	-	2023	-	-	-
1-1/2 in.	37.5 mm	5174	-	4842	-	-	-
	35.5 mm	-	-	-	-	-	-
1-1/4 in.	31.5 mm	5175	5340	4843	5009	-	-
	28 mm	3384	-	2022	-	-	-
1.06 in.	26.5 mm	5176	5342	4844	5010	-	-
1 in.	25 mm	5177	-	4845	5011	-	-
7/8 in.	22.4 mm	5178	-	4846	-	-	-
	20 mm	3199	-	2266	-	-	-
3/4 in.	19 mm	5179	5345	4847	5013	-	-
	18 mm	2355	-	2548	3337	-	-
5/8 in.	16 mm	5180	5346	4848	5014	-	-
	14 mm	2987	-	2020	-	-	-
.530 in.	13.2 mm	5181	5347	4849	5015	-	-
1/2 in.	12.5 mm	5182	5348	4850	5016	-	-
7/16 in.	11.2 mm	5183	5349	4851	5017	-	-
	10 mm	2645	3257	3193	-	-	-
3/8 in.	9.5 mm	5184	5350	4852	5018	-	-
	9 mm	2766	-	2547	-	-	-
5/16 in.	8 mm	5185	5351	4853	5020	-	-
	7.1 mm	3045	-	2647	-	-	-
.265 in.	6.7 mm	5186	5352	4854	5019	-	-
1/4 in.	6.3 mm	5187	5353	4855	5021	-	-
No. 3-1/2	5.6 mm	5188	5354	4856	5022	-	-
	5 mm	2550	2519	2016	3368	-	-
No. 4	4.75 mm	5189	5355	4857	5023	-	-
	4.5 mm	2256	2891	2990	-	-	-
No. 5	4 mm	5190	5356	4858	5024	-	-
	3.55 mm	2205	2892	3240	3072	-	-
No. 6	3.35 mm	5191	5357	4859	5025	-	-
*1/8 in.	3.15 mm	2058	3279	3281	2059	-	-
No. 7	2.8 mm	5192	5358	4860	5026	-	-
	2.5 mm	2207	2877	2015	3369	-	-
No. 8	2.36 mm	5193	5359	4861	5027	-	-
	2.24 mm	2347	2890	3242	-	-	-
No. 10	2 mm	5194	5360	4862	5028	-	-
	1.8 mm	2327	2117	3299	2637	-	-
No. 12	1.7 mm	5195	5361	4863	5029	-	-

8" DIAMETER TEST SIEVES

Designation		Stainless Frame- Stainless Cloth		Brass Frame- Stainless Cloth		Brass Frame- Brass Cloth	
USA	Supplementary	Full Ht. Part No.	Half Ht. Part No.	Full Ht. Part No.	Half Ht. Part No.	Full Ht. Part No.	Half Ht. Part No.
	1.6 mm	2326	2118	2613	2638	-	-
No. 14	1.4 mm	5196	5362	4864	5030	4532	4698
	1.25 mm	2352	2876	2282	2639	-	-
No. 16	1.18 mm	5197	5363	4865	5031	4533	4699
	1.12 mm	2253	2120	3229	2864	-	-
No. 18	1 mm	5198	5364	4866	5032	4534	4700
	900 µm	2904	2121	2663	2865	-	-
No. 20	850 µm	5199	5365	4867	5033	4535	4701
	800 µm	2274	2122	2202	2640	-	-
No. 25	710 µm	5200	5366	4868	5034	4536	4702
	630 µm	2372	2123	2201	2641	-	-
No. 30	600 µm	5201	5367	4869	5035	4537	4703
	560 µm	2975	2124	2286	2866	-	-
No. 35	500 µm	5202	5368	4870	5036	4538	4704
	450 µm	2275	2805	3359	2867	-	-
No. 40	425 µm	5203	5369	4871	5037	4539	4705
	400 µm	2450	2126	3249	2868	-	-
No. 45	355 µm	5204	5370	4872	5038	4540	4706
	315 µm	2276	2127	2199	2642	-	-
No. 50	300 µm	5205	5371	4873	5039	4541	4707
	280 µm	3106	3301	3107	2869	-	-
No. 60	250 µm	5206	5372	4874	5040	4542	4708
	224 µm	2983	3343	3232	2870	-	-
No. 70	212 µm	5207	5373	4875	5041	4543	4709
	200 µm	2277	2130	2198	3248	-	-
No. 80	180 µm	5208	5374	4876	5042	4544	4710
	160 µm	2278	2875	2197	2254	-	-
No. 100	150 µm	5209	5375	4877	5043	4545	4711
	140 µm	2873	3332	2657	3399	-	-
No. 120	125 µm	5210	5376	4878	5044	4546	4712
	112 µm	2763	3494	2852	3398	-	-
No. 140	106 µm	5211	5377	4879	5045	4547	4713
	100 µm	2279	2387	2196	2844	-	-
No. 170	90 µm	5212	5378	4880	5046	4548	4714
	80 µm	2451	2874	2195	2255	-	-
No. 200	75 µm	5213	5379	4881	5047	4549	4715
	71 µm	2872	2915	2553	3370	-	-
No. 230	63 µm	5214	5380	4882	5048	4550	4716
	56 µm	2725	2916	2850	3397	-	-
No. 270	53 µm	5215	5381	4883	5049	4551	4717
	50 µm	2724	3331	2224	2843	-	-
No. 325	45 µm	5216	5382	4884	5050	4552	4718
	40 µm	2718	3437	2851	3396	-	-
No. 400	38 µm	5217	5383	4885	5051	-	-
	36 µm	3049	-	2986	-	-	-
No. 450	32 µm	5256	5389	4887	2113	-	-
No. 500	25 µm	5218	5384	4886	5052	-	-
No. 635	20 µm	5257	5391	2295	2296	-	-

8" DIAMETER TEST SIEVES

GOLD SERIES TEST SIEVES

Designation		Stainless Frame - Stainless Cloth	
USA	Metric	Full Ht. Part No.	Half Ht. Part No.
No. 20	850 µm	5199G	5365G
No. 25	710 µm	5200G	5366G
No. 30	600 µm	5201G	5367G
No. 35	500 µm	5202G	5368G
No. 40	425 µm	5203G	5369G
No. 45	355 µm	5204G	5370G
No. 50	300 µm	5205G	5371G
No. 60	250 µm	5206G	5372G
No. 70	212 µm	5207G	5373G
No. 80	180 µm	5208G	5374G
No. 100	150 µm	5209G	5375G
No. 120	125 µm	5210G	5376G
No. 140	106 µm	5211G	5377G
No. 170	90 µm	5212G	5378G
No. 200	75 µm	5213G	5379G
No. 230	63 µm	5214G	5380G
No. 270	53 µm	5215G	5381G
No. 325	45 µm	5216G	5382G
No. 400	38 µm	5217G	5383G
No. 500	25 µm	5218G	5384G

Notes:

- Guarantees that the permissible variation of average opening as allowed by ASTM E11 is reduced by 50%.
- Designed as "masters" for internal quality assurance programs (8 in. diameter).
- Each test sieve is optically examined, serialized, and supplied with complete NIST Traceable Documents.

Top Covers	
Item	Part #
Stainless	8496
Stainless with Ring	8497
Brass	8487
Brass with Ring	8488
Bottom Pans	
Item	Part #
Stainless - Full Height	8491
Stainless - Half Height	8492
Brass - Full Height	8481
Brass - Half Height	8482
Intermediate Pans	
Item	Part #
Stainless with Skirt - Full Height	8493
Stainless with Skirt - Half Height	8494
Brass with Skirt - Full Height	8483
Brass w/ Skirt - Half Height	8484

Notes:

- 30 mesh backing cloth is available on test sieves 100 mesh and finer at an additional cost.
- Conforms to ISO 3310-1 and BS410 Specifications and ASTM E11
- 1/8" inch opening is not included in ASTM E11 Standard

12" DIAMETER TEST SIEVES



12" DIAMETER TEST SIEVES

Designation		Stainless Frame- Stainless Cloth			Brass Frame- Stainless Cloth			Brass Frame- Brass Cloth	
USA	Supplementary	Full Ht. Part No.	Inter. Ht. Part No.	Half Ht. Part No.	Full Ht. Part No.	Inter. Ht. Part No.	Half Ht. Part No.	Full Ht. Part No.	Half Ht. Part No.
4 in.	100 mm	6635	2300	6801	6967	7200	2297	-	-
3-1/2 in.	90 mm	6636	9109	6802	6968	7201	2298	-	-
	80 mm	-	-	-	2425	-	-	-	-
3 in.	75 mm	6637	2155	6803	6969	7202	7135	-	-
	71 mm	-	-	-	-	-	-	-	-
2-1/2 in.	63 mm	6638	9281	6804	6970	7203	7136	-	-
	56 mm	-	-	-	2485	-	-	-	-
2.12 in.	53 mm	6639	2301	6805	6971	7204	7137	-	-
2 in.	50 mm	6640	9282	6806	6972	7205	7138	-	-
1-3/4 in.	45 mm	6641	6705	6807	6973	7206	7139	-	-
	40 mm	3374	-	3414	2343	-	-	-	-
1-1/2 in.	37.5 mm	6642	9193	6808	6974	7207	7140	-	-
	35.5 mm	-	-	-	-	-	-	-	-
1-1/4 in.	31.5 mm	6643	9194	6809	6975	7208	7141	-	-
	28 mm	-	-	-	2095	-	2464	-	-
1.06 in.	26.5 mm	6644	2302	6810	6976	7209	7142	-	-
1 in.	25 mm	6645	9195	6811	6977	7210	7143	-	-
7/8 in.	22.4 mm	6646	6704	6812	6978	7211	7144	-	-
	20 mm	2367	-	3516	2028	3119	2465	-	-
3/4 in.	19 mm	6647	9196	6813	6979	7212	7145	-	-
	18 mm	2173	-	3140	2831	-	-	-	-
5/8 in.	16 mm	6648	9411	6814	6980	7213	7146	-	-
	14 mm	3065	-	2997	2029	-	2466	-	-
.530 in.	13.2 mm	6649	9431	6815	6981	7214	7147	-	-
1/2 in.	12.5 mm	6650	9197	6816	6982	7215	7148	-	-
7/16 in.	11.2 mm	6651	6702	6817	6983	7216	7149	-	-
	10 mm	2174	-	2998	2030	3118	2467	-	-
3/8 in.	9.5 mm	6652	9198	6818	6984	7217	7150	-	-
	9 mm	2344	-	-	3048	-	3057	-	-
5/16 in.	8 mm	6653	6703	6819	6985	7218	7151	-	-
	7.1 mm	-	-	-	3165	3324	3009	-	-
.265 in.	6.7 mm	6654	2303	6820	6986	7219	7152	-	-
1/4 in.	6.3 mm	6655	9199	6821	6987	7220	7153	-	-
No. 3-1/2	5.6 mm	6656	2218	6822	6988	7221	7154	-	-
	5 mm	2164	-	2495	2000	3117	2468	-	-
No. 4	4.75 mm	6657	9280	6823	6989	7222	7155	-	-
	4.5 mm	-	-	-	2952	-	-	-	-
No. 5	4 mm	6658	9098	6824	6990	7223	7156	-	-
	3.55 mm	2389	-	-	3241	-	-	-	-
No. 6	3.35 mm	6659	9113	6825	6991	7224	7157	-	-
*1/8 in.	3.15 mm	2761	-	2486	2573	2486	3293	-	-
No. 7	2.8 mm	6660	9098	6826	6992	7225	7158	-	-
	2.5 mm	2165	-	-	2349	3116	3036	-	-
No. 8	2.36 mm	6661	9100	6827	6993	7226	7159	6329	6495
	2.24 mm	-	-	-	2211	-	-	-	-
No. 10	2 mm	6662	9214	6828	6994	7227	7160	6330	6496
	1.8 mm	2564	-	-	2212	-	3010	-	-
No. 12	1.7 mm	6663	9136	6829	6995	7228	7161	6331	6497

12" DIAMETER TEST SIEVES

Designation		Stainless Frame- Stainless Cloth			Brass Frame- Stainless Cloth			Brass Frame- Brass Cloth	
USA	Supplementary	Full Ht. Part No.	Inter. Ht. Part No.	Half Ht. Part No.	Full Ht. Part No.	Inter. Ht. Part No.	Half Ht. Part No.	Full Ht. Part No.	Half Ht. Part No.
	1.6 mm	2694	-	-	2341	3333	-	-	-
No. 14	1.4 mm	6664	9271	6830	6996	7229	-	6332	6498
	1.25 mm	2166	-	3413	2348	3115	7162	-	-
No. 16	1.18 mm	6665	9148	6831	6997	7230	3505	6333	6499
	1.12 mm	2756	-	-	-	-	7163	-	-
No. 18	1 mm	6666	9079	6832	6998	7231	-	6334	6500
	900 µm	2615	-	3411	3467	-	7164	-	-
No. 20	850 µm	6667	9080	6833	6999	7232	7165	6335	6501
	800 µm	2616	-	3415	3466	-	-	-	-
No. 25	710 µm	6668	9081	6834	7000	7233	7166	6336	6502
	630 µm	2167	-	2999	3176	3114	3506	-	-
No. 30	600 µm	6669	9082	6835	7001	7234	7167	6337	6503
	560 µm	2617	-	-	-	-	-	-	-
No. 35	500 µm	6670	9083	6836	7002	7235	7168	6338	6504
	450 µm	2678	-	-	-	-	-	-	-
No. 40	425 µm	6671	9084	6837	7003	7236	7169	6339	6505
	400 µm	2618	-	3412	3465	3292	-	-	-
No. 45	355 µm	6672	9085	6838	7004	7237	7170	6340	6506
	315 µm	2168	-	3387	3175	3113	3507	-	-
No. 50	300 µm	6673	9086	6839	7005	7238	7171	6341	6507
	280 µm	-	-	-	-	-	-	-	-
No. 60	250 µm	6674	9087	6840	7006	7239	7172	6342	6508
	224 µm	3491	-	-	3093	-	7173	-	-
No. 70	212 µm	6675	9149	6841	7007	7240	3320	6343	6509
	200 µm	2619	-	-	-	-	-	-	-
No. 80	180 µm	6676	9215	6842	7008	7241	7174	6344	6510
	160 µm	2169	-	2365	2733	3112	3346	-	-
No. 100	150 µm	6677	9088	6843	7009	7242	7175	6345	6511
	140 µm	2620	-	-	2735	-	-	-	-
No. 120	125 µm	6678	9089	6844	7010	7243	7176	6346	6512
	112 µm	3158	-	-	-	-	-	-	-
No. 140	106 µm	6679	9010	6845	7011	7244	7177	6347	6513
	100 µm	2623	-	-	-	-	-	-	-
No. 170	90 µm	6680	9090	6846	7012	7245	7178	6348	6514
	80 µm	2621	-	3388	2462	3111	-	-	-
No. 200	75 µm	6681	9091	6847	7013	7246	7179	6349	6515
	71 µm	-	-	-	-2948	-	-	-	-
No. 230	63 µm	6682	9092	6848	7014	7247	2976	6350	6516
	56 µm	-	-	-	-	-	7180	-	-
No. 270	53 µm	6683	9093	6849	7015	7248	7181	6351	6517
	50 µm	2622	-	-	-	-	-	-	-
No. 325	45 µm	6684	9094	6450	7016	7249	7182	6352	6518
	40 µm	2624	-	-	-	-	-	-	-
No. 400	38 µm	6685	9013	6851	7017	7250	7183	-	-
	36 µm	-	-	-	-	-	-	-	-
No. 450	32 µm	6762	2304	6856	2299	7251	2153	-	-
No. 500	25 µm	6686	9212	6852	7018	7252	7184	-	-

12" DIAMETER TEST SIEVES

Top Covers	
Item	Part #
Stainless	8536
Stainless with Ring	8537
Brass	8530
Brass with Ring	8531
Bottom Pans	
Item	Part #
Stainless - Full Height	8532
Stainless - Half Height	8533
Brass - Full Height	8526
Brass - Half Height	8527
Intermediate Pans	
Item	Part #
Stainless with Skirt - Full Height	8534
Stainless with Skirt - Half Height	8535
Brass with Skirt - Full Height	8528
Brass w/ Skirt - Half Height	8529

Overall Height - Full: 4-1/4 Intermediate: 3 in. Half: 2-5/8 in.

Depth To Cloth - Full: 3-1/4 Intermediate: 2 in. Half: 1-5/8 in.

Notes:

- 30 mesh backing cloth is available on test sieves 100 mesh and finer available at an additional cost
- 1/8 in. opening is not included in ASTM E11 Standard

3" DIAMETER TEST SIEVES



3" DIAMETER TEST SIEVES

Designation		Stainless Frame- Stainless Cloth		Brass Frame- Stainless Cloth	
USA	Metric	Full Ht. Part No.	Half Ht. Part No.	Full Ht. Part No.	Half Ht. Part No.
No. 3-1/2	5.6 mm	1285	1700	1534	1617
	5 mm	3451	-	-	-
No. 4	4.75 mm	1286	1701	1535	1618
	4.5 mm	-	-	-	-
No. 5	4 mm	1287	1702	1536	1619
	3.55 mm	-	-	-	-
No. 6	3.35 mm	1288	1703	1537	1620
	3.15 mm	-	-	-	-
No. 7	2.8 mm	1289	1704	1538	1621
	2.5 mm	-	-	-	-
No. 8	2.36 mm	1290	1705	1539	1622
	2.24 mm	-	-	-	-
No. 10	2 mm	1291	1706	1540	1623
	1.8 mm	6525	-	-	-
No. 12	1.7 mm	1292	1707	1541	1624
	1.6 mm	-	-	-	-
No. 14	1.4 mm	1293	1708	1542	1625
	1.25 mm	3499	2743	-	-
No. 16	1.18 mm	1294	1709	1543	1626
	1.12 mm	-	2744	-	-
No. 18	1 mm	1295	1710	1544	1627
	900 µm	3314	2745	4240	3197
No. 20	850 µm	1296	1711	1545	1628
	800 µm	2483	2494	3245	-
No. 25	710 µm	1297	1712	1546	1629
	630 µm	2971	2746	-	-
No. 30	600 µm	1298	1713	1547	1630
	560 µm	3171	2747	-	-
No. 35	500 µm	1299	1714	1548	1631
	450 µm	3373	2748	-	-
No. 40	425 µm	1300	1715	1549	1632
	400 µm	2556	2749	2759	-
No. 45	355 µm	1301	1716	1550	1633
	315 µm	-	2329	-	-
No. 50	300 µm	1302	1717	1551	1634
	280 µm	-	2330	-	-
No. 60	250 µm	1303	1718	1552	1635
	224 µm	3271	2750	-	-
No. 70	212 µm	1304	1719	1553	1636
	200 µm	-	2493	2757	-
No. 80	180 µm	1305	1720	1554	1637
	160 µm	3095	-	-	-
No. 100	150 µm	1306	1721	1555	1638
	140 µm	2949	-	-	-
No. 120	125 µm	1307	1722	1556	1639
	112 µm	-	-	-	-
No. 140	106 µm	1308	1723	1557	1640
	100 µm	2248	2492	-	3473
No. 170	90 µm	1309	1724	1558	1641
	80 µm	2249	2330	-	3474

3" DIAMETER TEST SIEVES

Designation		Stainless Frame- Stainless Cloth		Brass Frame- Stainless Cloth	
USA	Metric	Full Ht. Part No.	Half Ht. Part No.	Full Ht. Part No.	Half Ht. Part No.
No. 200	75 µm	1310	1725	1559	1642
	71 µm	-	-	-	-
No. 230	63 µm	1311	1726	1560	1643
	56 µm	-	-	-	3469
No. 270	53 µm	1312	1727	1561	1644
	50 µm	2481	2491	-	3470
No. 325	45 µm	1313	1728	1562	1645
	40 µm	3440	3217	-	3471
No. 400	38 µm	1314	1729	1563	1646
	36 µm	-	-	-	3472
No. 450	32 µm	1324	1730	1565	1648
No. 500	25 µm	1315	1731	1564	1647
No. 635	20 µm	1325	1732	1566	1649

Overall Height: Full: 1 – ¾ in. Half 1 – ¼ in.

Depth to Cloth: Full: 1 – 1/4 in. Half 5/8 in.

Top Covers	
Item	Part #
Stainless	8411
Stainless w/ Ring	8412
Brass	8413
Brass w/ Ring	8414

Bottom Pans	
Item	Part #
Stainless- Full Ht.	8407
Stainless- Half Ht.	8408
Stainless w/ Skirt- Full Ht.	8409
Stainless w/ Skirt- Half Ht.	8410
Brass- Full Ht.	8401
Brass Half Ht.	8402
Brass w/ Skirt- Full Ht.	8403
Brass w/ Skirt- Half Ht.	8404

200MM DIAMETER TEST SIEVES



200MM DIAMETER TEST SIEVES

Designation		Stainless Frame- Stainless Cloth		Brass Frame- Stainless Cloth	
Metric	USA	Full Ht. Part No.	Half Ht. Part No.	Full Ht. Part No.	Half Ht. Part No.
37.5 mm	1-1/2 in.	7256	7340	9714	9814
31.5 mm	1-1/4 in.	7257	7341	9715	9815
28 mm	-	7258	7342	9716	9816
26.5 mm	1.06 in.	7259	7343	9717	9817
25 mm	1 in.	7260	7344	9718	9818
22.4 mm	7/8 in.	7261	7345	9719	9819
20 mm	-	7262	7346	9720	9820
19 mm	3/4 in.	7263	7347	9721	9821
18 mm	-	7264	7348	9722	9822
16 mm	5/8 in.	7265	7349	9723	9823
14 mm	-	7266	7350	9724	9824
13.2 mm	.530 in.	7267	7351	9725	9825
12.5 mm	1/2 in.	7268	7352	9726	9826
11.2 mm	7/16 in.	7269	7353	9727	9827
10 mm	-	7270	7354	9728	9828
9.5 mm	3/8 in.	7271	7355	9729	9829
9 mm	-	7272	7356	9730	9830
8 mm	5/16 in.	7273	7357	9731	9831
7.1 mm	-	7274	7358	9732	9832
6.7 mm	.265 in.	7275	7359	9733	9833
6.3 mm	1/4 in.	7276	7360	9734	9834
5.6 mm	No. 3-1/2	7277	7361	9735	9835
5 mm	-	7278	7362	9736	9836
4.75 mm	No. 4	7279	7363	9737	9837
4.5 mm	-	7280	7364	9738	9838
4 mm	No. 5	7281	7365	9739	9839
3.55 mm	-	7282	7366	9740	9840
3.35 mm	No. 6	7283	7367	9741	9841
3.15 mm	1/8 in.	7284	7368	9742	9842
2.8 mm	No. 7	7285	7369	9508	9608
2.5 mm	-	7286	7370	9509	9609
2.36 mm	No. 8	7287	7371	9510	9610
2.24 mm	-	7288	7372	9511	9611
2 mm	No. 10	7289	7373	9512	9612
1.8 mm	-	7290	7374	9513	9613
1.7 mm	No. 12	7291	7375	9514	9614
1.6 mm	-	7292	7376	9515	9615
1.4 mm	No. 14	7293	7377	9516	9616
1.25 mm	-	7294	7378	9517	9617
1.18 mm	No. 16	7295	7379	9518	9618
1.12 mm	-	7296	7380	9519	9619
1 mm	No. 18	7297	7381	9520	9620
900 µm	-	7298	7382	9521	9621
850 µm	No. 20	7299	7383	9522	9622
800 µm	-	7300	7384	9523	9623
710 µm	No. 25	7301	7385	9524	9624
630 µm	-	7302	7386	9525	9625
600 µm	No. 30	7303	7387	9526	9626
560 µm	-	7304	7388	9527	9627

200MM DIAMETER TEST SIEVES

Designation		Stainless Frame- Stainless Cloth		Brass Frame- Stainless Cloth	
Metric	USA	Full Ht. Part No.	Half Ht. Part No.	Full Ht. Part No.	Half Ht. Part No.
500 µm	No. 35	7305	7389	9528	9628
450 µm	-	7306	7390	9529	9629
425 µm	No. 40	7307	7391	9530	9630
400 µm	-	7308	7392	9531	9631
355 µm	No. 45	7309	7393	9532	9632
315 µm	-	7310	7394	9533	9633
300 µm	No. 50	7311	7395	9534	9634
280 µm	-	7312	7396	9535	9635
250 µm	No. 60	7313	7397	9536	9636
224 µm	-	7314	7398	9537	9637
212 µm	No. 70	7315	7399	9538	9638
200 µm	-	7316	7400	9539	9639
180 µm	No. 80	7317	7401	9540	9640
160 µm	-	7318	7402	9541	9641
150 µm	No. 100	7319	7403	9542	9642
140 µm	-	7320	7404	9543	9643
125 µm	No. 120	7321	7405	9544	9644
112 µm	-	7322	7406	9545	9645
106 µm	No. 140	7323	7407	9546	9646
100 µm	-	7324	7408	9547	9647
90 µm	No. 170	7325	7409	9548	9648
80 µm	-	7326	7410	9549	9649
75 µm	No. 200	7327	7411	9550	9650
71 µm	-	7328	7412	9551	9651
63 µm	No. 230	7329	7413	9552	9652
56 µm	-	7330	7414	9553	9653
53 µm	No. 270	7331	7415	9554	9654
50 µm	-	7332	7416	9555	9655
45 µm	No. 325	7333	7417	9556	9656
40 µm	-	7334	7418	9557	9657
38 µm	No. 400	7335	7419	9558	9658
36 µm	-	7336	7420	9794	9894
32 µm	No. 450	7337	7421	9795	9895
25 µm	No. 500	7338	7422	9797	9897
20 µm	No. 635	7339	7423	9799	9899

Overall Height: Full: 65mm Half: 47mm

Depth to Cloth: Full: 50mm Half: 32mm

Top Covers	
Item	Part #
Stainless	9902
Brass	9902M

Bottom Pans	
Item	Part #
Stainless- Full Ht.	9901
Stainless- Half Ht.	9903
Brass- Full Ht.	9901M
Brass Half Ht.	9903M

300MM DIAMETER TEST SIEVES



300MM DIAMETER TEST SIEVES

Designation		Stainless Frame- Stainless Cloth	
Metric	USA	Full Ht. Part No.	Half Ht. Part No.
37.5 mm	1-1/2 in.	8173	8257
31.5 mm	1-1/4 in.	8174	8258
28 mm	-	8175	8259
26.5 mm	1.06 in.	8176	8260
25 mm	1 in.	8177	8261
22.4 mm	7/8 in.	8178	8262
20 mm	-	8179	8263
19 mm	3/4 in.	8180	8264
18 mm	-	8181	8265
16 mm	5/8 in.	8182	8266
14 mm	-	8183	8267
13.2 mm	.530 in.	8184	8268
12.5 mm	1/2 in.	8185	8269
11.2 mm	7/16 in.	8186	8270
10 mm	-	8187	8271
9.5 mm	3/8 in.	8188	8272
9 mm	-	8189	8273
8 mm	5/16 in.	8190	8274
7.1 mm	-	8191	8275
6.7 mm	.265 in.	8192	8276
6.3 mm	1/4 in.	8193	8277
5.6 mm	No. 3-1/2	8194	8278
5 mm	-	8195	8279
4.75 mm	No. 4	8196	8280
4.5 mm	-	8197	8281
4 mm	No. 5	8198	8282
3.55 mm	-	8199	8283
3.35 mm	No. 6	8200	8284
3.15 mm	-	8201	8285
2.8 mm	No. 7	8202	8286
2.5 mm	-	8203	8287
2.36 mm	No. 8	8204	8288
2.24 mm	-	8205	8289
2 mm	No. 10	8206	8290
1.8 mm	-	8207	8291
1.7 mm	No. 12	8208	8292
1.6 mm	-	8209	8293
1.4 mm	No. 14	8210	8294
1.25 mm	-	8211	8295
1.18 mm	No. 16	8212	8296
1.12 mm	-	8213	8297
1 mm	No. 18	8214	8298
900 µm	-	8215	8299
850 µm	No. 20	8216	8300
800 µm	-	8217	8301
710 µm	No. 25	8218	8302
630 µm	-	8219	8303
600 µm	No. 30	8220	8304
560 µm	-	8221	8305
500 µm	No. 35	8222	8306
450 µm	-	8223	8307
425 µm	No. 40	8224	8308

300MM DIAMETER TEST SIEVES

Designation		Stainless Frame- Stainless Cloth	
Metric	USA	Full Ht. Part No.	Half Ht. Part No.
400 µm	-	8225	8309
355	No. 45	8226	8310
315 µm	-	8227	8311
300 µm	No. 50	8228	8312
280 µm	-	8229	8313
250 µm	No. 60	8230	8314
224 µm	-	8231	8315
212 µm	No. 70	8232	8316
200 µm	-	8233	8317
180 µm	No. 80	8234	8318
160 µm	-	8235	8319
150 µm	No. 100	8236	8320
140 µm	-	8237	8321
125 µm	No. 120	8238	8322
112 µm	-	8239	8323
106 µm	No. 140	8240	8324
100 µm	-	8241	8325
90 µm	No. 170	8242	8326
80 µm	-	8243	8327
75 µm	No. 200	8244	8328
71 µm	-	8245	8329
63 µm	No. 230	8246	8330
56 µm	-	8247	8331
53 µm	No. 270	8248	8332
50 µm	-	8249	8333
45 µm	No. 325	8250	8334
40 µm	-	8251	8335
38 µm	No. 400	8252	8336
36 µm	-	8253	8337
32 µm	No. 450	8254	8338
25 µm	No. 500	8255	8339

Overall Height: Full: 75mm Half: 45mm

Depth to Cloth: Full: 60mm Half: 30mm

Top Covers	
Item	Part #
Stainless	8342
Bottom Pans	
Item	Part #
Stainless- Full Height	8345
Stainless- Full Height	8346

Notes:

- Each Test Sieve is supplied with a Serial No. and a matching Test Sieve Certificate of Compliance
- Conforms to current ISO 3310-1 and BS410 Specifications

NON-STANDARD TEST SIEVES



6" DIAMETER TEST SIEVES

Designation		Stainless Frame- Stainless Cloth	
USA	Metric	Full Ht. Part No.	Half Ht. Part No.
1 in.	25 mm	3845	-
7/8 in.	22.4 mm	3846	-
3/4 in.	19 mm	3847	-
5/8 in.	16 mm	3848	-
.530 in.	13.2 mm	3849	-
1/2 in.	12.5 mm	3850	-
7/16 in.	11.2 mm	3851	-
3/8 in.	9.5 mm	3852	-
5/16 in.	8 mm	3853	-
.265 in.	6.7 mm	3854	-
1/4 in.	6.3 mm	3855	-
No. 3-1/2	5.6 mm	3856	4022
No. 4	4.75 mm	3857	4023
No. 5	4 mm	3858	4024
No. 6	3.35 mm	3859	4025
No. 7	2.8 mm	3860	4026
No. 8	2.36 mm	3861	4027
No. 10	2 mm	3862	4028
No. 12	1.7 mm	3863	4029
No. 14	1.4 mm	3864	4030
No. 16	1.18 mm	3865	4031
No. 18	1 mm	3866	4032
No. 20	850 µm	3867	4033
No. 25	710 µm	3868	4034
No. 30	600 µm	3869	4035
No. 35	500 µm	3870	4036
No. 40	425 µm	3871	4037
No. 45	355 µm	3872	4038
No. 50	300 µm	3873	4039
No. 60	250 µm	3874	4040
No. 70	212 µm	3875	4041
No. 80	180 µm	3876	4042
No. 100	150 µm	3877	4043
No. 120	125 µm	3878	4044
No. 140	106 µm	3879	4045
No. 170	90 µm	3880	4046
No. 200	75 µm	3881	4047
No. 230	63 µm	3882	4048
No. 270	53 µm	3883	4049
No. 325	45 µm	3884	4050
No. 400	38 µm	3885	4051
No. 450	32 µm	3889	4053
No. 500	25 µm	3886	4052

Overall Height: Full: 2 – 5/8 in. Half: 1 – 7/8 in.

Depth to Cloth: Full: 1 – 3/4 in. Half: 1 in.

6" DIAMETER TEST SIEVES

Top Covers	
Item	Part #
Stainless	8471
Stainless with Ring	8472
Bottom Pans	
Item	Part #
Stainless- Full Height	8467
Stainless with Skirt	8469
Intermediate Pans	
Item	Part #
Stainless – Full Height with Skirt	8469

Notes:

- 30 mesh backing cloth is available on test sieves 100 mesh and finer
- ASTM supplementary sizes available

AGRICULTURE

We have been at the forefront of the agricultural industry since setting the standards with the very first test sieve.

10" DIAMETER TEST SIEVES

Designation		Stainless Frame- Stainless Cloth
USA	Metric	Full Ht. Part No.
4 in.	100 mm	5799
3-1/2 in.	90 mm	5800
3 in.	75 mm	5801
2-1/2 in.	63 mm	5802
2.12 in.	53 mm	5803
2 in.	50 mm	5804
1-3/4 in.	45 mm	5805
1-1/2 in.	37.5 mm	5806
1-1/4 in.	31.5 mm	5807
1.06 in.	26.5 mm	5808
1 in.	25 mm	5809
7/8 in.	22.4 mm	5810
3/4 in.	19 mm	5811
5/8 in.	16 mm	5812
.530 in.	13.2 mm	5813
1/2 in.	12.5 mm	5814
7/16 in.	11.2 mm	5815
3/8 in.	9.5 mm	5816
5/16 in.	8 mm	5817
.265 in.	6.7 mm	5818
1/4 in.	6.3 mm	5819
No. 3-1/2	5.6 mm	5820
No. 4	4.75 mm	5821
No. 5	4 mm	5822
No. 6	3.35 mm	5823
No. 7	2.8 mm	5824
No. 8	2.36 mm	5825
No. 10	2 mm	5826
No. 12	1.7 mm	5827
No. 14	1.4 mm	5828
No. 16	1.18 mm	5829
No. 18	1 mm	5830
No. 20	850 µm	5831
No. 25	710 µm	5832
No. 30	600 µm	5833
No. 35	500 µm	5834
No. 40	425 µm	5835
No. 45	355 µm	5836
No. 50	300 µm	5837
No. 60	250 µm	5838
No. 70	212 µm	5839
No. 80	180 µm	5840
No. 100	150 µm	5841
No. 120	125 µm	5842
No. 140	106 µm	5843
No. 170	90 µm	5844
No. 200	75 µm	5845

Overall Height: Full 4 in.

Depth to Cloth: Full: 3 in.

10" DIAMETER TEST SIEVES

Top Covers	
Item	Part #
Stainless	8516
Stainless with Ring	8517

Bottom Pans	
Item	Part #
Stainless- Full Ht.	8512
Stainless w/ Skirt	8514

Notes:

- 30 mesh backing cloth is available on test sieves 100 mesh and finer.

MINING & MINERAL PROCESSING

Accuracy and durability in your screening process is a huge factor in your productivity – it's this process that drives us to continue to improve and provide the best.



18" DIAMETER TEST SIEVES

Designation		Stainless Frame- Stainless Cloth	Brass Frame- Stainless Cloth
USA	Metric	Part No.	Part No.
4 in.	100 mm	4189	7503
3-1/2 in.	90 mm	4190	7504
3 in.	75 mm	4191	7505
2-1/2 in.	63 mm	4192	7506
2.12 in.	53 mm	4193	7507
2 in.	50 mm	4194	7508
1-3/4 in.	45 mm	4195	7509
1-1/2 in.	37.5 mm	4196	7510
1-1/4 in.	31.5 mm	4197	7511
1.06 in.	26.5 mm	4267	7512
1 in.	25 mm	4199	7513
7/8 in.	22.4 mm	4200	7514
3/4 in.	19 mm	4201	7515
5/8 in.	16 mm	4202	7516
.530 in.	13.2 mm	4203	7517
1/2 in.	12.5 mm	4204	7518
7/16 in.	11.2 mm	4205	7519
3/8 in.	9.5 mm	4206	7520
5/16 in.	8 mm	4207	7521
.265 in.	6.7 mm	4208	7522
1/4 in.	6.3 mm	4209	7523
No. 3-1/2	5.6 mm	4210	7524
No. 4	4.75 mm	4211	7525
No. 5	4 mm	4212	7526
No. 6	3.35 mm	4213	7527
*1/8	3.15 mm	4251	3382
No. 7	2.8 mm	4214	7528
No. 8	2.36 mm	4215	7529
No. 10	2 mm	4216	7530
No. 12	1.7 mm	4217	7531
No. 14	1.4 mm	4218	7532
No. 16	1.18 mm	4219	7533
No. 18	1 mm	4220	7534
No. 20	850 µm	4221	7535
No. 25	710 µm	4222	7536
No. 30	600 µm	4223	7537
No. 35	500 µm	4224	7538
No. 40	425 µm	4225	7539
No. 45	355 µm	4226	7540
No. 50	300 µm	4227	7541
No. 60	250 µm	4228	7542
No. 70	212 µm	4229	7543
No. 80	180 µm	4230	7544
No. 100	150 µm	4231	7545
No. 120	125 µm	4232	7546
No. 140	106 µm	4260	7547
No. 170	90 µm	4234	7548
No. 200	75 µm	4235	7549
No. 230	63 µm	4262	7550

Overall Height: 5 – 1/2 in.

Depth to Cloth: 4 – 1/2 in.

18" DIAMETER TEST SIEVES

Top Covers	
Item	Part #
Brass	8558
Stainless Steel	4238

Bottom Pans	
Item	Part #
Brass	8556
Stainless Steel	4237

Notes:

- 30 mesh backing cloth is available on test sieves 100 mesh and finer.
- 1/8 in. opening is not included in ASTM E11 Standard
- ASTM Supplementary sizes available



MEDICAL & PHARMACEUTICAL

Trusted professionals in this industry have used our particle analysis equipment in various environments – including cleanroom conditions.

WET WASH TEST SIEVES



WET WASH TEST SIEVES

8-inch diameter x 4 inch depth	
Overall Height	4 – 5/8 inch
Depth to Cloth	4 – 1/8 inch
8-inch diameter x 8 inch depth	
Overall Height	8 – 5/8 inch
Depth to Cloth	8 – 1/8 inch
3-inch diameter x 4 inch depth	
Overall Height	4 inches
Depth to Cloth	3 inches
12-inch diameter x 8 inch depth	
Overall Height	9 inches
Depth to Cloth	8 inches

Notes:

- All wet wash test sieves include drain holes in the lower frame
- 30 mesh backing is recommended for US #200 and finer
- ASTM supplementary sizes available

FOOD & BEVERAGE

We work diligently to provide the highest quality products that you can trust.



CERTIFICATION AND TESTING SERVICES



CERTIFICATION AND TESTING SERVICES



Test sieves and shakers are finely-calibrated measuring devices, which must be certified, checked in operation, and regularly monitored. For these reasons, W.S. Tyler provides comprehensive test certificates and service for all of our products for ongoing, regulation-compliant quality assurance.

The necessary tests can be carried out at two confidence levels as a certifying and calibrating measurement. For calibration, two times as many meshes are measured as compared to certification, thereby achieving a higher level of statistical reliability. Finally, the measurements are evaluated separately in the warp and weft directions and the results saved for subsequent checks. Our services are applicable for both new and in-use test sieves.

The Primary Standards that govern Test Sieves are ASTM E11 and ISO

3310-1. Both W.S. Tyler and its parent organization, Haver & Boecker, Germany, are very active on the committees that write and oversee the Standards. By contributing our many years of expertise to the various committees, the marketplace can rely on the Standards to be valuable and practical to the product users.

NATIONAL INSTITUTE OF STANDARDS AND TECHNOLOGY (NIST) TRACEABILITY

All of W.S. Tyler’s Laboratory Services offer some degree of traceability directly to National Institute of Standards and Technology (NIST) W.S. Tyler’s laboratory examinations are performed with an automatic, non-contact, dimensional measurement system with an accuracy of +/- 0.5 of a micron. W.S. Tyler, on average, performs 10,000 examinations per year in our on-site working laboratories.

Recommended in-use sieve re-certification schedule	
Aperture	Schedule*
5 in. – 1/4 in.	80 uses or 36 months
US # 3-1/2 – US # 12	70 uses or 30 months
US # 14 – US # 40	60 uses or 24 months
US # 45 – US # 140	50 uses or 18 months
US # 170 – US # 325	40 uses or 12 months
US # 400 – US # 635	20 uses or 6 months
*Whichever comes last	

CERTIFICATION AND TESTING SERVICES

Certified Test Sieve – Part #9998

ASTM E11 Equivalent - Inspection Grade

- New and in-use Test Sieves
- Openings measured with a computerized video imaging system; +/- .5 microns
- Examined to the current ASTM and ISO specifications
- Products are serialized and supplied with NIST traceable document including statistical information on opening sizes and wire diameters

Certified Test Sieve – Part #9992

ASTM E11 Equivalent – Calibration Grade

- New and in-use Test Sieves
- Openings measured with a computerized video imaging system; +/- .5 microns
- Examined to the current ASTM and ISO specifications
- Products are serialized and supplied with NIST traceable document including statistical information on opening sizes and wire diameters
- Increased number of measurements provide a 99.73% level of confidence (k-factor) vs. the Inspection Grade

Particle Analysis Services – Part #9995

- Performed in W.S. Tyler in-house lab
- Fine, dry applications from 2 in. through US #635 (20 μ m)
- SDS sheet must be provided when applicable
- Service includes detailed analysis of results

Matched / Certified Test Sieve – Part #9991

- Individually performance tested against W.S. Tyler Master Series Sieves
- Performance test result tolerances: +/- 2.5%
- Certified including NIST Traceable & Performance Test Documents
- Designed for critical multiple location comparison analysis
- US # 8 – US # 325, 8 inch diameter, stainless steel cloth sieves ONLY

W.S. Tyler offers a performance matching service for companies with multiple testing locations, seeking data that is comparable for all labs. Matched test sieves are performance tested on a Ro-Tap against a set of Master Test sieves using a known sample. To be considered a Matched test sieve, the new sieve's sample results must fall within +/- 2.5% of the Master results. Once a sieve has been approved as Matched, it is certified to the ASTM E11 Inspection grade.

CERTIFICATION AND TESTING SERVICES

A Upper Spec. = Aperture size per ASTM E11 specification, plus tolerance

B Lower Spec. = Aperture size per ASTM E11 specification, minus tolerance

C Max. Measured = The largest aperture per ASTM E11 specification

D Standard Deviation = A numerical value that measures "spreading" tendency, a deviation of the values from their mean (average)

E Nominal = Specified aperture size per ASTM E11 specification

F Mean = Average aperture size or wire diameter measured

G Max. Measured = The largest aperture or wire diameter measured

H Min. Measured = The smallest aperture or wire diameter measured

I Range = The difference between the "max" and "min" above (rounded)

J Mean = Average aperture size or wire diameter measured, also known as the Actual Standard Deviation

K Histogram = Graphic presentation of values measured vs. corresponding number of apertures examined

L Serial No. = Identification number of test sieves

M Sieve Mesh Designation = Test sieve designation / mesh size

N Sample Size = Number of apertures or wire diameters measured

W.S. Tyler Certified, Certified Plus and Matched test sieves are examined to meet ASTM and ISO specifications.

The openings of the sieves are measured with a computerized video imaging system. Products are then serialized and supplied with NIST traceable documents, including statistical information on opening sizes and wire diameters.

Shown here is a typical Document of Certification and descriptions of the terms used.

For more information, contact a W.S. Tyler representative at 1-800-321-6188 or by email at info@wstyler.com

CERTIFICATION AND TESTING SERVICES

Certified Date : 12/04/19
 Company Name : XXXXXX
 Certification Standard : ASTM E11
 Certification Grade : Calibration Grade Test Sieve Certification
 (Certified Plus Test Sieves)

L Serial Number : 8-FH-SS-SS-No.270
 Sieve Manufacturer : W.S. Tyler
M Sieve Mesh Designation : #170
N No. of Measurements : 160
 Type of Weave : Plain Weave
 Mesh Material : Stainless Steel
 Sieve Material : Stainless Steel
 Sieve Diameter : X"
 Sieve Height : X"
 Unit of measurement : μm

- New Certification
- Re-certification
- Sieve Visually Inspected
- Sieve Cleaned

Opening Size

Maximum Allowable Average Opening	:	1.44181 mm	A
Minimum Allowable Average Opening	:	1.35819 mm	B
Maximum Allowable Individual Opening	:	1.55935 mm	C
Maximum Allowable Standard Deviation	:	0.05035	D
Nominal Opening	:	1.4 mm	E

F Your Actual X Opening Mean:
1.41744 mm

Your Actual Y Opening Mean:
1.38592 mm

G Actual Maximum Opening : **1.4454 mm**
H Actual Minimum Opening : **1.37565 mm**
I Actual Range : **0.06975 mm**
J Actual Standard Deviation : **0.01874**

Actual Maximum Opening : **1.42143 mm**
 Actual Minimum Opening : **1.36475 mm**
 Actual Range : **0.05668 mm**
 Actual Standard Deviation : **0.01212**

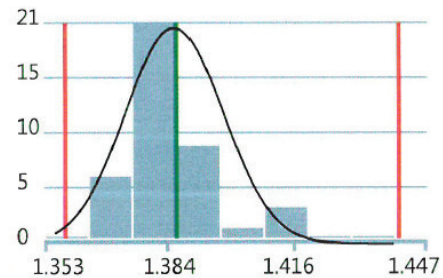
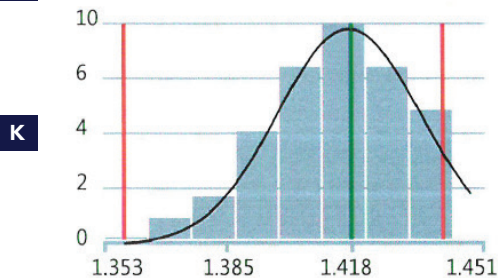

Wire Diameter

Maximum Allowable Average Wire Diameter	:	0.82 mm
Minimum Allowable Average Wire Diameter	:	0.6 mm
Nominal Wire Diameter	:	0.71 mm

Your Actual X Wire Diameter Mean:
0.73623 mm

Your Actual Y Wire Diameter Mean:
0.70465 mm

USEFUL TIPS ON CARE AND CLEANING OF TEST SIEVES



A TEST SIEVE IS A PRECISION SCIENTIFIC INSTRUMENT.

- Care should be taken when handling a Sieve to avoid damage to the frame and the sometimes delicate, sensitive Test Sieve mesh.
- Test sieves should be cleaned after each use.
- Test sieves should be stored in a clean, dry, controlled environment.
- Test sieves should be inspected regularly for mesh damage.

FOR PROPER CLEANING A SOFT BRISTLE BRUSH SHOULD BE USED.

- Turn the sieve over, place over a receiving pan and gently brush the underside of the mesh using a circular motion NOT applying excessive pressure.
- Gently tap the sieve frame with the brush handle to remove any particles that may cling to the frame.
- Sieves may be washed in a warm water, synthetic detergent solution.
- The Sieve must be dried before the next use.
- An oven may be used in the drying process, temperatures not to exceed 190 degrees F.
- An ultrasonic bath may also be used to clean test sieves, (review cleaning unit instructions prior to use, see page 60).

For cleaning service, contact a W.S.Tyler representative at 1-800-321-6188 or by email at info@wstyler.com

W.S. TYLER RO-TAP®



**EXPLORE THE
W.S. TYLER RO-TAP®
IN ACTION AT
WWW.WSTYLER.COM**



RO-TAP® RX-29 AND RX-30 MODELS

The industry standard in test sieve shakers, the original W.S. Tyler Ro-Tap® has a unique two-dimensional operation: a horizontal, circular motion, and a vertical tapping motion. This special action allows material particles to stratify and “seek” critical openings in the test media. This unit provides the most accurate and consistent particle analysis testing and requires minimal maintenance. The RX-29 is designed for testing with 8-inch diameter test sieves. The RX-30 model is designed for testing with 12 in. diameter test sieves. Each unit is test run and serialized prior to shipment and features a 99-minute digital timer/clock with a tolerance of .1 seconds.



Number of Sieves		
Model	Full Height	Half Height
RX-29 (8 in. or 200 mm diameter)	6 sieves with full height pan	13 sieves with half height pan
RX-30 (12 in. or 300 mm diameter)	4 sieves with full height pan	8 sieves with half height pan
RX-30 (12 in. or 300 mm diameter)	6 sieves with half height pan	8 sieves with half height pan

At 1725 RPM, 60 Cycle Current		
Description	Part #	
115v (8 in. test sieve)	RX-29	
230v (8 in. test sieve)	RX-29-16	
115v (12 in. test sieve)	RX-30	
230v (12 in. test sieve)	RX-30-16	

At 1425 RPM, 50 Cycle Current		
Description	Part #	
115v (8 in. test sieve)	RX-29-2	
230v (8 in. test sieve)	RX-29-10	
115v (12 in. test sieve)	RX-30-2	
230v (12 in. test sieve)	RX-30-10	

Specifications	
Oscillations per Minute	278 ± 10
Oscillations Displacement	1-1/8 in. x 7/16 in.
Taps per Minute	150 ± 10
Dimensions	28 in. wide x 21 in. deep x 25 in. high (71 cm x 54 cm x 64 cm)
Weight	180 lbs. (82 kg)
Testing Applications	RX-29: 2 in. through US #635 mesh (20 µm) RX-30: 4 in. through US #500 mesh (25 µm)

RO-TAP® RX-29 AND RX-30 PARTS DIAGRAM

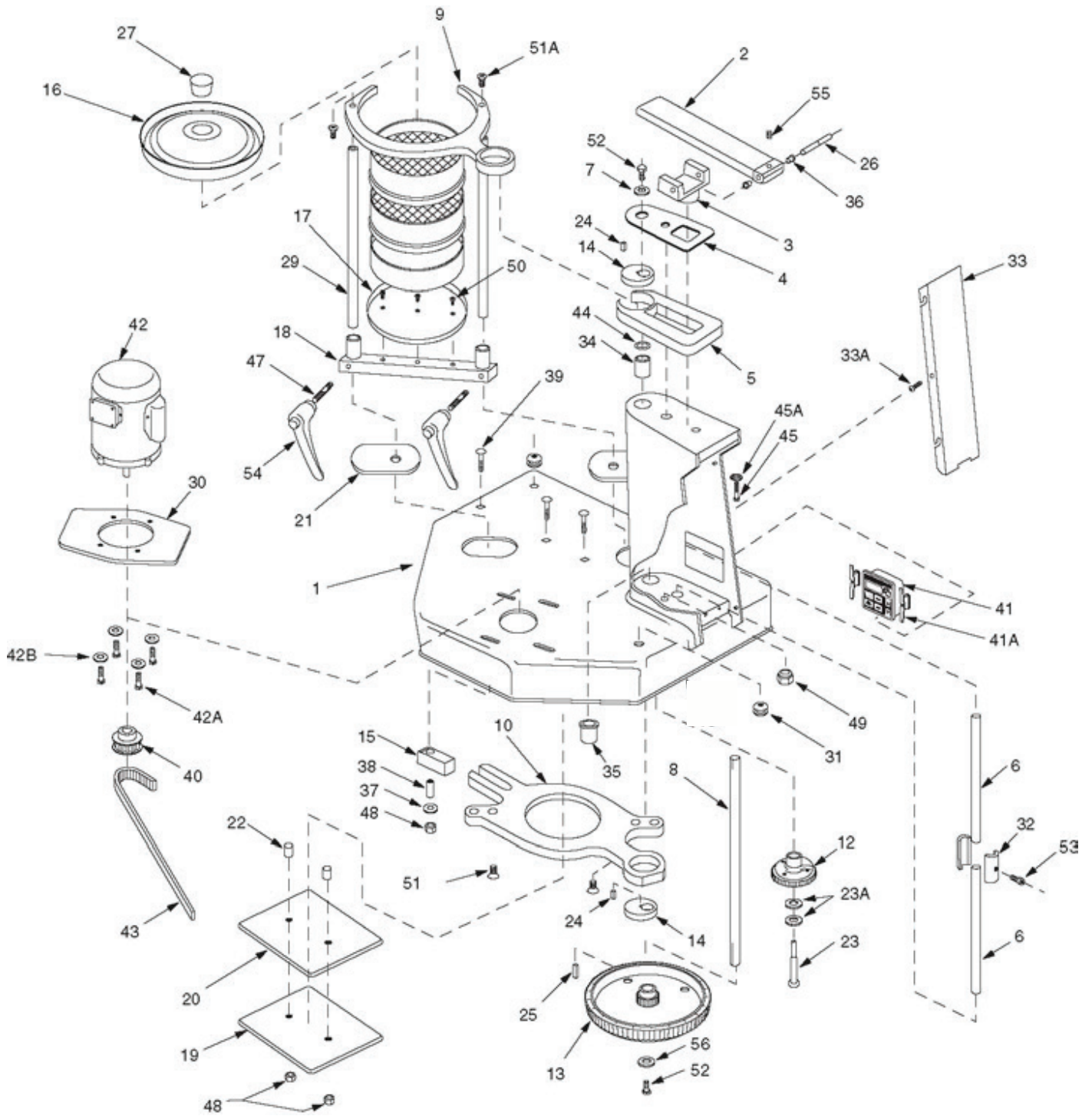

RO-TAP® RX-29 AND RX-30 PARTS

Item #	Part #	Description	Required
1	107770	Base	1
2	R-20029	Hammer	1
3	R-20023	Hammer Block	1
4	R-30019	Sheet Guard	1
5	R-30010	Rotating Guard	1
6	R-10036	Lift Rod	2
7	R-10038	Upper Main Shaft Washer	1
8	R-20027	Main Shaft	1
9	R-30008	Upper Carrying Plate: RX-29 (plastic)	1
9A	R-30008-1	Upper Carrying Plate: RX-29 (heavy-duty cast aluminum)	1
9B	R-30027	Upper Carrying Plate: RX-30 (steel)	1
10	R-30009	Lower Carrying Plate	1
12	R-20039	Cam Gear	1
13	R-30015	Timing Belt Pulley	1
14	R-10034	Eccentric Discs	2
15	R-10032	Block	1
16	R-30007	Sieve Cover (RX-29)	1
	R-30011	Sieve Cover (RX-30)	1
17	R-30006	Sieve Support Plate (RX-29)	1
	R-30013	Sieve Support Plate (RX-30)	1
18	R-30023	Sieve Support Clamp Bar (RX-29)	1
	R-30022	Sieve Support Clamp Bar (RX-30)	1
19	R-20019	Backup Plate	1
20	R-20020	Bearing Plate	1
21	R-20033	Shield	2
22	R-10028	Tube Spacer	2
23	R-10029	Cam Shoulder Screw	1
23A	106582	1/2 in. ID Shim	2
24	R-10042	Main Shaft Key – Eccentric	2
25	R-10039	Main Shaft Key – Lower	1
26	R-10035	Hammer Pin	1
27	R-10066-A	Cork Plug (10 per pk.)	1 pk.
29	R-10033	Tie Rod	2
30	R-30018	Motor Adapter	1
31	ZA11167	Grommet	2
32	R-10030	Lift Rod Coupling (2-1/2 in. long)	1
33	R-40011	Pedestal Cover	1
34	R-10061	Flange Bushing	1
35	R-10062	Bearing	1
36	R-10063	Flange Bearing	2
37	ZF10168	Thrust Washer	1
38	R-10065	Steel Bushing	1
39	ZF10174	3/8-16 NC x 2-1/4 in. Carriage Bolt	3
40	R-10070	Sprocket w/ Set Screw: 14 teeth (1800 RPM)	1
	R-10048	Sprocket w/ Set Screw: 17 teeth (1500 RPM)	1
41	R-40029	Electronic Timer: 115v	1
	R-40037	Electronic Timer: 230v	1
41 A	R-40040	Timer Clips	2
42	RP-1500-23	Motor: 1/4 HP (115v/230v) (60Hz/50Hz) 1 Phase	1
42A	ZF10183	3/8 -16 x 1 in. Long Hex Head Screw	4
42B	ZF10168	3/8 ID Flat Washer	4
43	R-10058	Timing Belt	1
44	R-10055	Shim	1
45	ZZ10068	1/2- 13 x 2-1/2 in. Long Head Bolt	1
45A	ZZ10323	1/2 ID Lock Washer	1
47	R-10079	Clamp Screw	2
48	ZF10221	3/8 in. Lock Nut	3
49	ZF10222	1/2 in. Lock Nut	1
50	ZF10231	10- 32 x 1/2 in. Long Flat Head Socket Cap Screw	3
51	ZF10241	3/8- 16 x 3/4 in. Long Flat Head Socket Cap Screw	2
51A	ZF10240	3/8- 16 x 3/4 in. Long Hex Head Screw	2
52	114162	3/8- 16 x .62 in. Long Hex Head Screw	2
53	ZF10251	5/16- 24 X 1-1/4 in. Long Socket Head Cap Screw	1
54	R-20082	Adjustable Handles (pair)	1
55	ZA10148	#10-24 x 1/4 in. Socket Head Set Screw	1
56	ZF10271	3/8 ID x 1-1/2 in. OD Fender Washer	1
60*	R-10017	Timer Cord w/ Plug (110v)	1
60A*	R-10017-220	Timer Cord w/ Plug (220v)	1

DISCOVER THE LEGACY OF W.S. TYLER TEST SIEVES AT WWW.WSTYLER.COM



RO-TAP® RX-94 MODEL

The RX-94 Test Sieve Shaker utilizes the same traditional design as the RX-29 model. In addition, the unit features a cavity that allows for two “stacks” of 8 in. or 200 mm diameter test sieves. This allows for twice the processing capacity in nominally the same time required to complete one test. The RX-94 model is designed for use with 8 in. or 200 mm diameter test sieves only and feature a newly designed easy lock clamping system. Each unit is test run and serialized prior to shipment and features a 99-minute digital timer with a tolerance of .1 seconds.



Model	Number of Sieves	
	Full Height	Half Height
RX-94 (8 in. or 200 mm diameter)	2 stacks of 6 sieves with	2 stacks of 13 sieves with half height pan

Description	Part #
115v 60Hz current	RX-94
230v 60Hz current	RX-94-1
115v 50Hz current	RX-94-2
230v 50Hz current	RX-94-3

Specifications	
Oscillations per Minute	278 ± 10
Oscillations Displacement	1 – 1/8 in. x 7/16 in.
Taps Per Minute	150 ± 10
Dimensions	30 in. wide x 27 deep x 26 in. high (75 cm x 68 cm x 56 cm)
Weight	220 lbs. (110 kg)
Testing Applications	2 in. through US #635 mesh (20 µm)

All models are wired with single phase current
Test sieves are sold separately

RO-TAP® RX-94 PARTS DIAGRAM

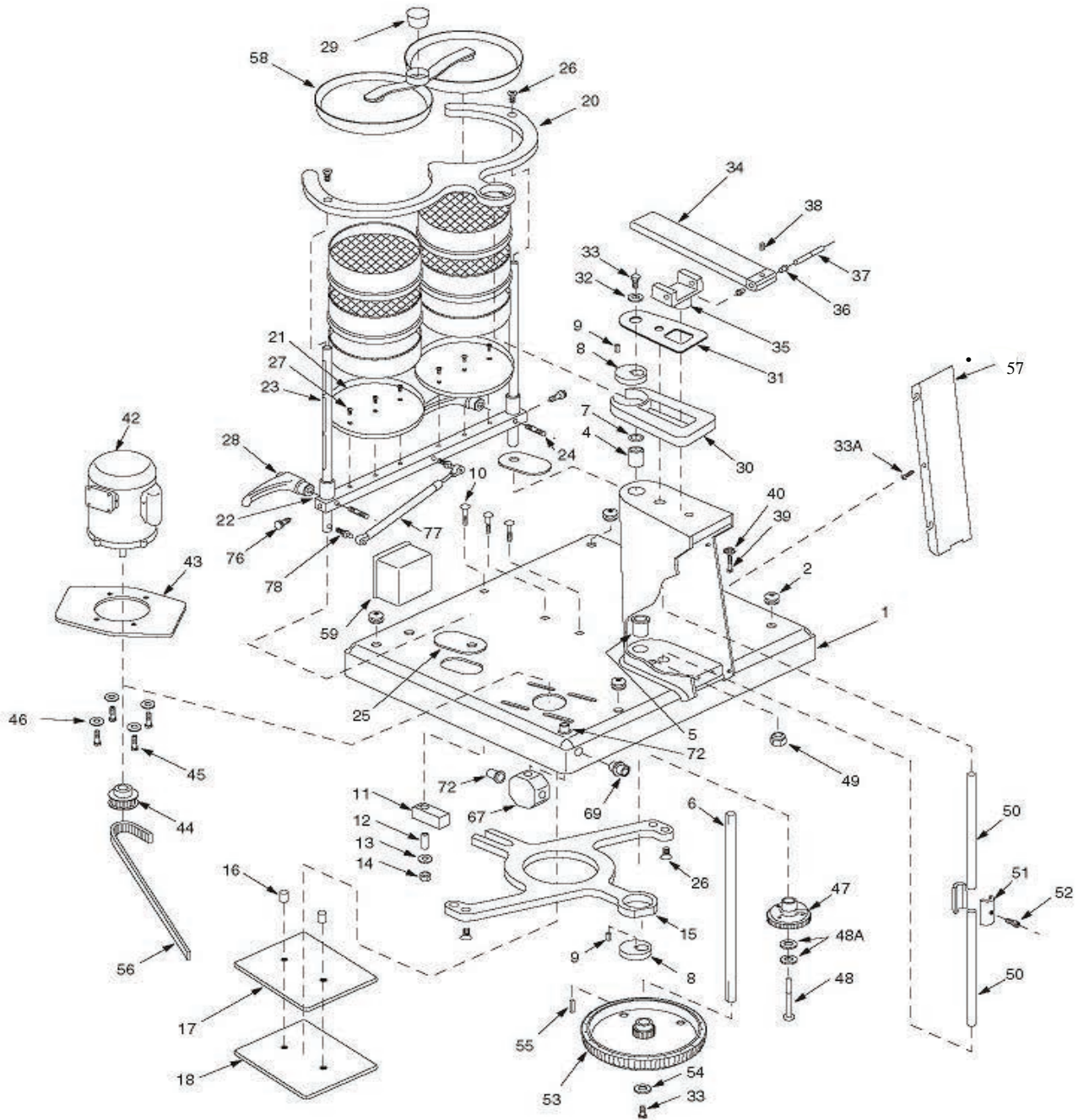

RO-TAP® RX-94 PARTS

Item #	Part #	Description	Required
1	R-40023	Painted Base Weldment	1
2	ZA11167	Grommet	4
4	R-10061	Flanged Bearing	1
5	R-10062	Bearing	1
6	R-20027	Main Shaft	1
7	R-10055	Shim 1.42 OD x .0155 Thick	1
8	R-10034	Eccentric Discs	2
9	R-10042	Main Shaft Key	2
10	ZF10174	3/8 -16 x 2-1/4 in. Carriage Bolt	3
11	R-10032	Block	1
12	R-10065	Steel Bushing .62 OD x .385 ID x 1-1/4 in.	1
13	ZF10168	3/8 in. Flat Washer	1
14	ZF10221	3/8 - 16 Locknut	1
15	R-40017	Lower Carrying Plate	1
16	R-10028	Tube Spacer	2
17	R-20020	Bearing Plate	1
18	R-20019	Back-up Plate	1
19	ZF10221	3/8 -16 Locknut	2
20	R-40019	Upper Carrying Plate	1
21	R-30006	Support Plate	2
22	R-40018	Dual Sieve Support Clamp Bar	1
23	R-40021	Tie Rod	2
24	R-10079	Clamp Screw	2
25	R-20033	Shield	2
26	ZF10241	3/8 -16 x 3/4 in. Long Flat Head Screw	4
27	ZF10231	#10-32 x 1/2 in. Long Flat Head Screw	6
28	R-20082	Adjustable Handles (pair)	1
29	R-10066-A	Cork Plug (10 per pk.)	1
30	R-30010	Rotating Guard Assembly	1
31	R-30019	Sheet Guard	1
32	R-10038	Upper Main Shaft Washer	1
33	114162	3/8 -16 x .62 Long Head Hex Cap Screw	2
34	R-20029	8 in. Hammer	1
35	R-20023	Hammer Block	1
36	R-10063	Flanged Bearing	2
37	R-10035	Hammer Pin	1
38	ZA10148	#10-24 x 1/4 in. Long Flat Point Socket Head Cap Screw	1
39	ZZ10068	1/2-13 x 2-1/2 in Long Hex Head Bolt	1
40	ZZ10068	1/2 ID Lock Washer	1
41*	R-10017	Stand Motor Cord w/ Plug	1
42	P-1500-23	Motor: 1/4 HP (115v/230v) (60Hz/50Hz) 1 Phase	1
43	R-30018	Motor Adapter Plate	1
44	R-10070	Sprocket -14 teeth (1800 RPM) w/ Set Screw	1
45	ZF10183	3/8- 16 x 1 in. Long Hex Head Screw	4
46	ZF10168	38/ ID Flat Washer	4
47	R-20039	Cam Gear	1
48	R-10029	Cam Shoulder Screw	1
48A	106582	1/2 ID Shim	2
49	ZF10222	1/2- 13 Locknut	1
50	R-10036	Lift Rod	2
51	R-10030	Lift Rod Coupling	1
52	ZF10251	5/16- 24 x 1-1/4 in. Long Socket Head Cap Screw	1
53	R-30015	Timing Belt Pulley	1
54	ZF10271	3/8 ID x 1-1/2 in. OD Fender Washer	1
55	R-10039	Main Shaft Key (lower)	1
56	R-10058	Timing Belt	1
57	R-40011	Pedestal Cover	1
58	R-40020	Dual Sieve Cover	1
59	R-40030	Timer Enclosure	1
60*	R-40029	Electronic Timer (115v)	1
60A*	R-40037	Electronic Timer (230v)	2
66	R-10118	3-1/4 in. Octagon Box (Appleton #30)	1
77	R-10099-30	Gas Spring (Guden #CGS24-30)	1
78	114165	Spring Stud (Guden #BS11-02)	2

RO-TAP® E SIEVE SHAKERS



RO-TAP E PURE



RO-TAP E PREMIUM



RO-TAP E PREMIUM REMOTE

The newly designed test sieve shaker stands out with its simple and quick operation. Two specific regulated amplitudes for coarse or fine material can be selected by the user. Sieving begins immediately once the timer is set and an amplitude has been selected. The Ro-Tap E is recommended as a basic machine for standard sieve analysis.

The Ro-Tap E Premium unit is one of two new W.S. Tyler Sieve Shaker offerings. This machine is our most quiet design ever with the improved dampening system. The control panel allows users to self select the amplitude and interval of the sieving motions.

The extra large display offers operators an excellent overview of the settings and is user-friendly. The new Ro-Tap E Premium unit is ideally suited for users who demand precision and reproducible sieve analysis.

The Ro-Tap E Premium Remote offers a separate control unit for wet sieve analysis. The design and function of the lid has been specifically developed for tests where water needs to be used to assist in the particle separation. The wide-spreading spray diffuser is integrated into the cover, offering improved handling. The cover includes an inspection glass which allows observation during the sieving process.

Model Name	Amplitude	Diameter Sieves	Wet Testing	Part #
E Pure	Fine and Coarse	8 in. or 200 mm	N	RX-29-E
E Premium	Adjustable up to 3 mm	8 in. or 200 mm	N	RX-29-E Premium
E Premium Remote	Adjustable up to 3 mm	8 in. or 200 mm	Y	550100
EML 315	Adjustable up to 3 mm	12 in. or 300 mm	Y	550075

RO-TAP® RX-812 MODEL

Designed to be used in coarse testing applications, the affordable RX-812 coarse sieve shaker has the unique capability of using both 8 in. and 12 in. diameter test sieves, simply by using the quick-change adapters provided. The RX-812 has a quiet operation and utilizes an effective action that gives consistent accurate results. The RX-812 is recommended for use with test sieves 100 mesh and coarser.



Model	Number of Sieves	
	Full Height	Half Height
RX-812 (8 in. or 200 mm diameter)	6 sieves	13 sieves
RX-812 (12 in. or 300 mm diameter)	4 sieves	6 sieves
	4 sieves	8 sieves

Description	Part #
115v 60Hz current	RX-812
230v 60Hz current	RX-812-1
115v 50Hz current	RX-812-2
230v 50Hz current	RX-812-3

Specifications	
Oscillations per Minute	280 ± 10 (60 HZ), 231 ± 10 (50Hz)
Oscillations Displacement	1 – 1/8 in. x 7/16 in.
Dimensions	23 in. wide x 15 deep x 13 in. high (59 cm x 38 cm x 33 cm)
Weight	55 lbs. (25 kg)
Testing Applications	80 mesh and coarser

All models are wired with single phase current.
Test sieves are sold separately.

RO-TAP® RX-812 PARTS DIAGRAM

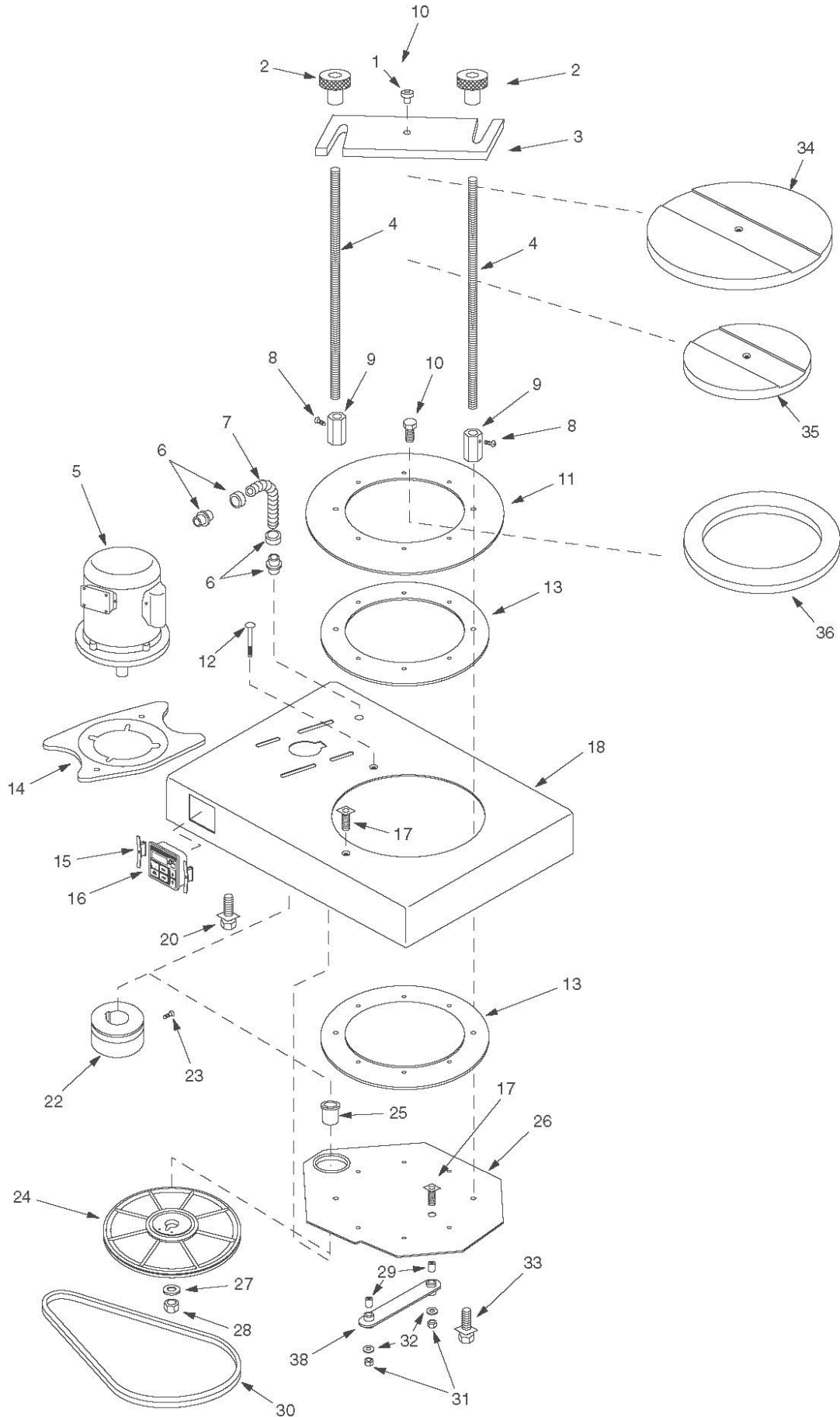

RO-TAP® RX-812 PARTS

Item #	Part #	Description	Required
1	LC10016	Locating Pin	1
2	LC10017	Clamping Knobs	2
3	LC10008	Clamp Bar	1
4	LC10015	Clamping Rods	2
5	P-1500-23	Motor: 1/4 HP (115v/230v) (60Hz/50Hz) 1 Phase	1
6	R-10112	Flexible Conduit Connector	2
7	102542	Oilite Flexible Conduit – 8-1/2 in.	1
8	ZA10956	10-24 Cup Point Set Screw	4
9	LC10014	Coupling	2
10	LB10266	Rolok 10-24 Self Tap Screw	6
11	LC10007	Shield	1
12	LB10041	Special Carriage Bolt	1
13	LC10005	Bearing Ring	2
14	R-30018	Adapter	1
15	R-40040	Timer Mounting Clip	2
16*	R-40029	Electronic Timer (115 v.)	1
	R-40037	Electronic Timer (230v.)	1
17	ZZ10792	1/4- 28 x 3/8 in. Cup Point Set Screw	2
18	LC10003	Base, Sieve Shaker	1
20	ZF10183	3/8 in. -16 x 1 in. Hex Head Bolt	3
22	LB10111	Drive Pulley (1-1/2 in. OD)	1
23	ZA10148	10-24 x 3/8 in. Cup Point Set Screw	1
24	LB10051	Pulley/ Eccentric Assembly	1
25	LB10191	Flanged Standoff Bushing	1
26	LC10006	Carrying Plate	1
27	ZF10168	3/8 in. Hard Washer	1
28	ZF10221	3/8 in. -16 Locknut	1
29	LB10201	Stand Off Bushing	2
30	LB10211	Drive Belt- 2L310	1
31	ZZ10801	1/4 in. -28 Black Lock Nut	2
32	ZZ10301	1/4 in. Flat Washer	6
33	ZF10184	5/16 in. -18 Black Hex Head Bolt	2
34	LC10010	12 in. Cover Clamping Plate	1
35	LC10011	8 in. Cover Clamping Plate	1
36	LC10009	12 in. to 8 in. Conversion Plate	1
37*	R-10018	110v Cord Set	1
38	LC10012	Arm	1

RO-TAP® SIEVE SHAKER MAINTENANCE

W.S. Tyler can also test the condition operation, and safety of test sieves shakers on your behalf, in our laboratory.

When tests are conducted in our factory, the units are subjected to comprehensive system diagnostics and special functionality tests on a test rig. These tests are used to determine and, if necessary, readjust the amplitude characteristics. Additionally, we assess the screening machines electrics, mechanics, and safety.

To ensure lasting dependable service Ro-Tap® Sieve Shakers must occasionally be upgraded with parts that are long-wearing, durable and cost effective. Maintenance kits are



available for the replacement of parts due to normal wear and tear. W.S. Tyler recommends the use of these kits as a means to minimize the down-time



due to minor repairs. The purchase of a minor maintenance kit is also recommended with each new Ro-Tap® Sieve Shaker.

Description	Includes:	Part #
Minor Maintenance Kit (RX-29, RX-30, & RX-94)	2 eccentric discs (R-10034) 1 Flange Bushing (R-10061) 1 Bearing (R-10062) 1 Cork Plug Pk. (R-10066-A) 2 Flange Bearings (R-10063)	10121
Major Maintenance Kit	1 Minor Maintenance Kit (10121) 1 Timing Belt (R-10058) 1 Upper Carrying Plate (R-30008) 1 Cam Gear (R-20039) 1 Timing Belt Pulley (R-30015)	10122
Maintenance Kit for (RX-94)	Kit Part # 10122 Without Part #R-30008	10123

Sieve Conversion Kit

Description	Part #
Ro-Tap® 12 in. diameter – 8 in. diameter test sieve kit	RX-32
Ro-Tap® 8 in. diameter – 3 in. diameter test sieve kit	RX-30033-1

We offer inserts for the standard Ro-Tap® to allow RX-30 to accept 8” sieves and RX-29 to accept 3” sieves.

Timer Conversion

Description	Part #
Ro-Tap® Digital Timer Conversion Kit – 115v	R-40038
Ro-Tap® Digital Timer Conversion Kit – 230v	R-40039

To replace turn knob timers on old RX-29 and RX-30.

LAB KIT & SAMPLING SPLITTERS

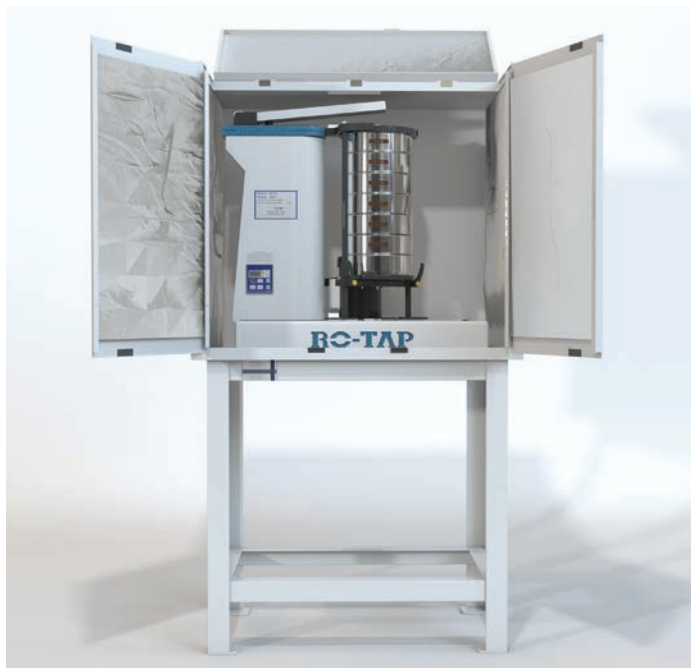

SOUND ENCLOSURE

W.S. Tyler's Sound Enclosure is designed to be used exclusively with Ro-Tap Sieve Shakers. The operating noise levels are reduced from approximately 85dB to 78 dB. The cabinets are fabricated with 18 gauge steel and a 1 in. metal faced acoustic foam inner liner.

TEST STAND

Specifically designed for W.S. Tyler's RX-29, RX-30, and RX-812 Sieve Shakers, the Test Stand can be used with or without the Sound Enclosure Cabinet. The test stand is fast and easy to install while offering an attractive and sturdy construction that can be fastened to the floor or foundation.

Description	Dimensions	Weight	Part #
Sound Enclosure (RX-29, RX-30)	35 in. wide x 24 in. deep x 29 in. high (89 cm x 60 cm x 74 cm)	125 lbs. (57 kg)	R-30050
Sound Enclosure (RX-94)	34 in. wide x 33 in. deep x 31 in. high (86 cm x 83 cm x 78 cm)	150 lbs. (69 kg)	RX-99
Test Stand (RX-29, RX-30, RX-812)	20 in. wide x 32 in. high x 28 in. deep (50 cm x 81 cm x 71 cm)	65 lbs. (30 kg)	R-40041
Cover Springs with Ball Stud (RX-99 only)	N/A	N/A	R-10099-30



SAMPLING SPLITTERS

Reduces or halves material samples for making sieve tests. The Splitters maintain representative particle size distribution while reducing the original sample size.



Description	Max Particle Size	Dimensions	Weight	Part #
Sample Splitter with 14-1/2 in. Discharge Chutes	1/8 in.	12 in. wide x 14 in. deep x 12 in. high (30 cm x 36 cm x 30 cm)	10 lbs. (5 kg)	SS-50
Sample Splitter with 16-1 in. Discharge Chutes	1/4 in.	22 in. wide x 16 in. deep x 16 in. high (56 cm x 41 cm x 41 cm)	25 lbs. (10 kg)	SS-100

THE SPINNING RIFFLER & ROTARY SIFTER

RX-230 SPINNING RIFFLER

The RX-230 Spinning Riffler uses a vibratory feeder to provide a constant flow of material from the stainless steel hopper. The vibrating feeder then feeds the sampling tubes from 1 to 16 individual samples. Each sample can then be capped and stored immediately, with minimal handling and little chance for outside contamination. Spin riffling is the method of choice for sampling accuracy and reliability for dry, free flowing particles. This unit will virtually eliminate operator error and bias associated with other types of sampling devices.

The RX-230 Spinning Riffler includes a sixteen-port dividing head, a set of sixteen standard tube sample vessels, a sample drum to contain the vessels and a hopper plate for positioning the vessels in the drum. All of these parts are available as replacement parts.



ROTARY SIFTER RX-20

The RX-20 Rotary Sifter offers a classic design and efficient operation in an economical package. A proven sieving method preferred by many DOT's, based on a popular design developed many years ago. The Rotary Sifter offers a faster conversion from 8 in. – 12 in. or 200 mm – 300 mm diameter sieves. The sieve stack capacity ranges from six 12 in. diameter full height sieves with a pan up to twenty 8 in. diameter half height sieves with pan.

The totally enclosed cabinet allows safe, dust-free operation. Individual tapping hammers assist passage of near-size particles. The digital timer has an LED display which precisely times operation up to 99 minutes at +/- 1 second. The system is driven by a 1/3HP continuous-duty motor, being an accurate and simple.

Description	Dimensions	Weight	Part #
Spinning Riffler (Dual Voltage)	13 in. wide x 20-1/2 in. deep x 23 in. high (33 cm x 52 cm x 58 cm)	25 lbs.	RX-230
Rotary Sifter	19 in. wide x 24 in. deep x 58 in. high (49 cm x 66 cm x 147 cm)	215 lbs.	RX-20

ULTRASONIC TEST SIEVE CLEANER & WET TEST SIEVING KIT



ULTRASONIC TEST SIEVE CLEANER

Produces ultrasonic vibrations in a cleaning fluid bath, which causes contaminants to become dislodged from both sieve frame and media.

- 8 in. or 200mm diameter test sieves only
- Compact and portable
- Stainless steel oscillation tank
- Built-in timer
- Solution NOT included (mild detergent recommended)
- Dimensions: 9-1/2 in. diameter x 10 in. high (24 cm x 25 cm)
- Unit Weight: 12 lbs. (6 kg.)

Description	Part #
Ultrasonic Test Sieve Cleaner	P-1405



Description	Dimensions	Part #
Nylon Brush	Used for cleaning sieves 120 mesh and finer	8577
Brass Brush	Used for cleaning sieves 100 mesh and coarser	8576

Model	Part #
RX-29	LA11112
RX-94	LA11194

W.S. TYLER CPA
(COMPUTERIZED PARTICLE ANALYZER)



W.S. TYLER CPA

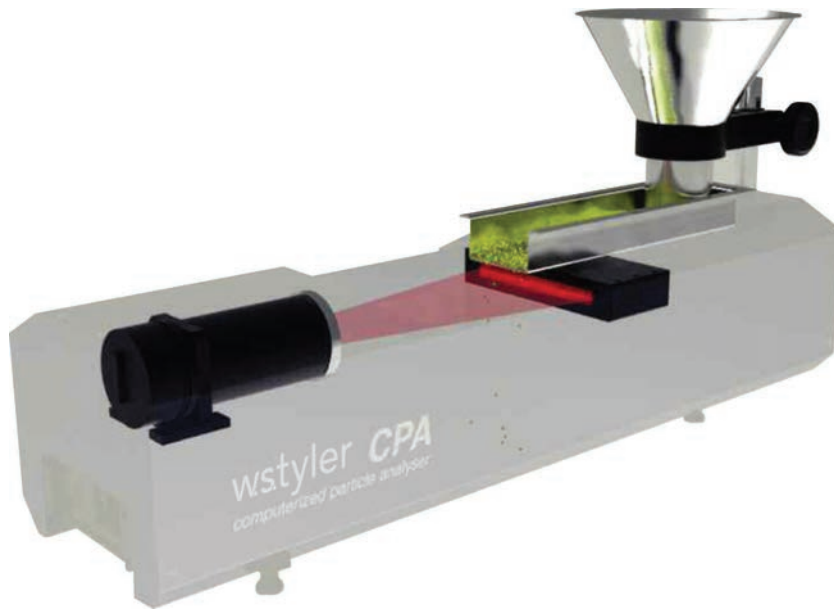

The patented W.S. Tyler CPA measuring process is used to analyze the grain sizes and shapes of dry and non-agglomerating particles of bulk materials in the range from 10 μ m to 400mm. The robust technology is virtually maintenance free; therefore, it is absolutely fail-safe and works reliably, even under extreme conditions. The CPA technology can be used to analyze coarse and fine material, such as gravel, sand, coal, plastic granules, wood chippings, chemical and pharmaceutical products, fertilizers, pet food and much more.



W.S. Tyler CPA systems are based upon energy-saving, low-maintenance technology that minimize operating costs. They are ready to connect to a PLC control system in their standard configuration and can also be integrated into online processes at a later date without modification. The results produced by the device are comparable with a conventional sieve analysis, but offer several decisive advantages, including high reproducibility of measuring results, enormous time saving, additional information related to particle shapes, and the number of particles.

W.S. Tyler CPA measuring instruments are based on digital image processing. A high-resolution, digital line-scan camera captures the particles in free-falling bulk materials against an LED lighting array. With a recording frequency reaching 28,000 line scans per second, the scanned lines are combined by the CPA to form an endless data record. The

shadow projections of the particles are evaluated in real time concurrent with the measuring process. Up to 10,000 particles can be detected, analyzed, and counted every second. Due to a GigE camera interface, the CPA devices can be operated using a notebook without additional hardware modules, such as a camera card. The GigE technology has a high transfer rate of up to 1 Gb per second.



For more information, contact a W.S.Tyler representative at 1-800-321-6188 or by email at info@wstyler.com

W.S. TYLER CPA

W.S. TYLER CPA LABORATORY UNITS

PHOTO-OPTICAL PARTICLE MEASURING INSTRUMENTS



DESIGNATION		CPA 2-1 HR	CPA 2-1	CPA 2 CONVEYOR
Number of measuring ranges	[-]	1	1	1
Measuring range	[mm]	0,010 - 4	0,020 - 30	0,036 - 45 non-spherical
Feeder width / Scanning width	[mm]	18	55	65
Conveyor width	[mm]	-	-	75
Hopper volume (approx.)	[l]	0,35	1,5	4
Application	[-]	Laboratory	Laboratory	Online / Laboratory
Light source	[-]	LED	LED	LED
Dimensions (appr.) (LxWxH)	[mm]	730 x 260 x 360	800 x 200 x 355	940 x 260 x 580
Weight (approx.)	[kg]	17	16	27
Operating voltage	[V]	230 or 115	230 or 115	230 or 115
Type of protection (standard)	[-]	IP 54	IP 54	IP 54
Interfaces	[-]	BUS-Ext., GigE, USB	BUS-Ext., GigE, USB	BUS-Ext., GigE, USB
Horizontal resolution	[Pixel]	2048	2927	2048
Pixel frequency	[MHz]	60	100	60



ADVANTAGES OF THE W.S. TYLER CPA 2-1:

- Laboratory unit for particle size and shape analysis in the measuring range from 20µm up to 30mm.
- Newest W.S. Tyler CpaServ software, intuitive handling, variety of analysis options
- Light weight easy to move
- Optimal reproducibility with short measurement times automatic feeder cleaning- LED light source, durable and energy-saving 1 Gb per second.

* Shown with ultrasonic adaptor

HOSOKAWA ALPINE AIR JET



HOSOKAWA ALPINE AIR JET E200 LS



The Hosokawa ALPINE Air Jet Sieve e200 LS has an attractive ergonomic design and fits nicely on a work bench. A high resolution 6.4" TFT touch screen allows intuitive operation with its easy-to-follow user interface. The integrated analysis guide leads you through comparison analysis, trend analyses for statistics, language switch-over, and setting of country-specific measurement units.

Because extremely fine particles have a tendency to agglomerate and therefore often clog up the sieve, the air jet sieve is the device of choice for sieving fine powders. As a result of the air jet principle, the e200 LS offers maximum effectiveness with such materials. The reason for this effectiveness is based on two components: a slotted nozzle which rotates in the sieving chamber and an industrial vacuum cleaner connected up to the sieving chamber. As soon as the vacuum cleaner is switched on, it generates a vacuum inside the sieving chamber.

The extremely narrow slot of the slotted nozzle ensures that the incoming air is accelerated and flows against the sieve fabric at high speed from below.

The particles on the sieve fabric are dispersed briefly by the air jet before they are drawn downwards through the sieve apertures by the suction of the vacuum cleaner. The coarse material remains on the sieve and is re-weighed at the end of the sieving process. The automatic underpressure controller as well as specification of the sieving-relevant parameters guarantee reproducible results.

SOFTWARE OPTIONS

eControl Basic

Simple sieving user level for quick individual analysis. Intuitive menu guidance makes for easy and reliable operation. Can be upgraded to higher software versions.

eControl Professional

Expanded package that includes interface with a balance and additional graphic display abilities. Graphic evaluation is plotted in a cumulative curve. Can be upgraded to higher software version.

For more information, contact a W.S.Tyler representative at 1-800-321-6188 or by email at info@wstyler.com

HOSOKAWA ALPINE AIR JET E200 LS

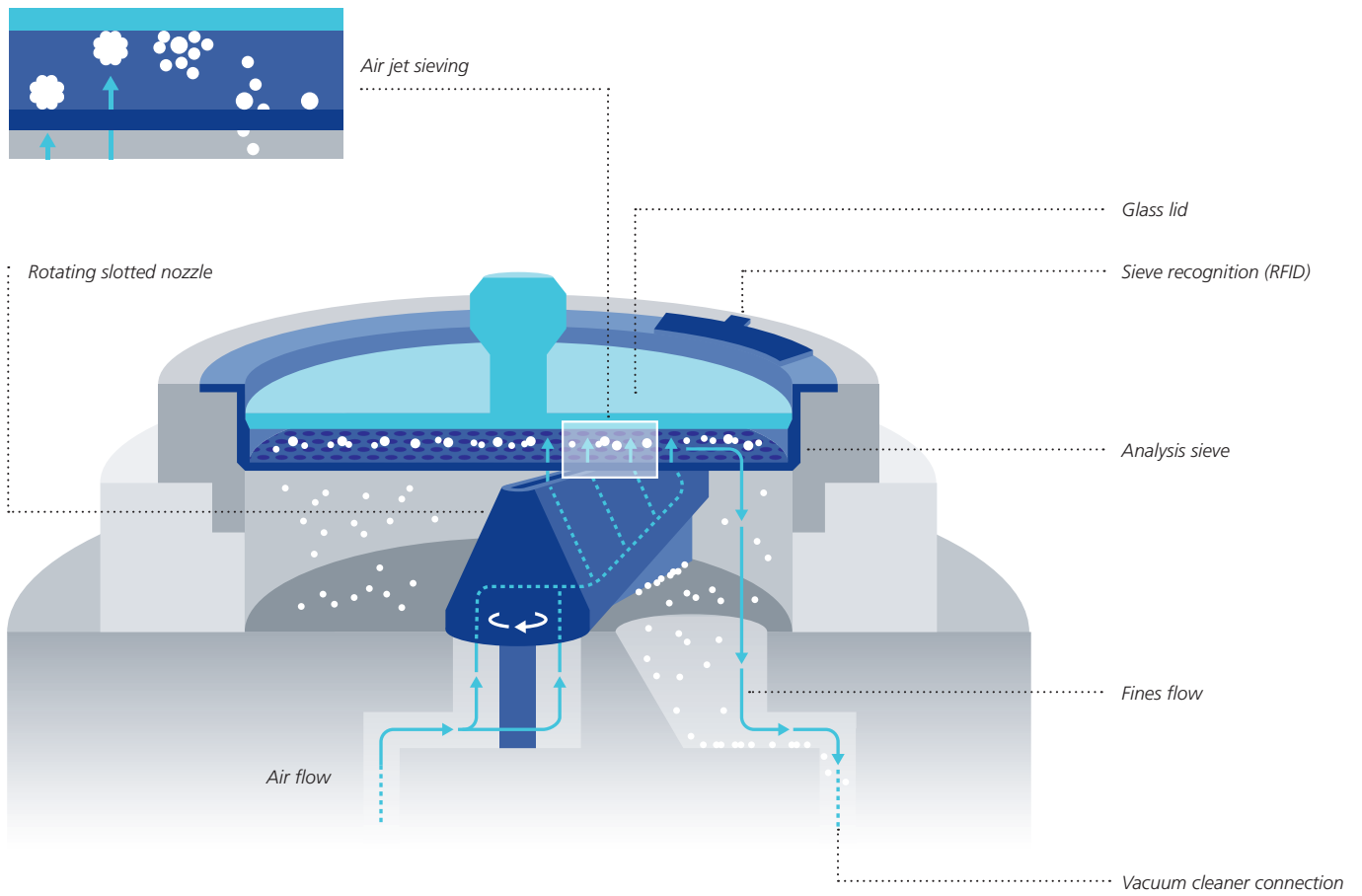

> Batch weight

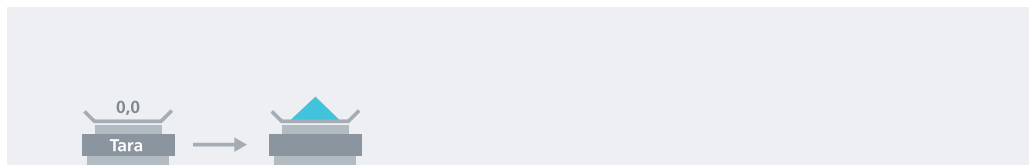

> Test sieve 1

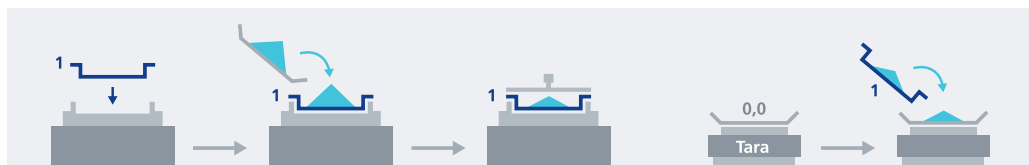

> Test sieve 2

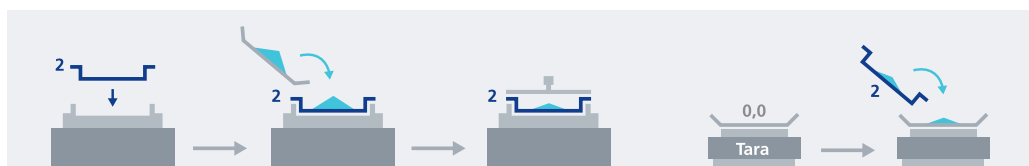

Sieving process

HOSOKAWA ALPINE SMART SIEVES FOR E200LS

Designation		Stainless Frame- Stainless Cloth
USA	Metric	Part No.
No. 5	4 mm	522260
No. 6	3.35 mm	522262
No. 7	2.8 mm	522265
No. 8	2.36 mm	522267
No. 10	2 mm	522269
No. 12	1.7 mm	522272
No. 14	1.4 mm	522274
No. 16	1.18 mm	522276
No. 18	1 mm	522278
No. 20	850 µm	522214
No. 25	710 µm	522216
No. 30	600 µm	522219
No. 35	500 µm	522221
No. 40	425 µm	522223
No. 45	355 µm	522226
No. 50	300 µm	522228
No. 60	250 µm	522230
No. 70	212 µm	522233
No. 80	180 µm	522235
No. 100	150 µm	522237
No. 120	125 µm	522239
No. 140	106 µm	522241
No. 170	90 µm	522243
No. 200	75 µm	522245
No. 230	63 µm	522247
No. 270	53 µm	522250
No. 325	45 µm	522252
No. 400	38 µm	522254
No. 450	32 µm	522257
No. 500	25 µm	522258
No. 635	20 µm	522259

Notes:

- All sieves 200 mm diameter
- For use with e200LS
- Each sieve is supplied with an ID Chip for instant recognition



ALPINE AIR JET SIEVES 200LS

Designation		Stainless Frame- Stainless Cloth
USA	Metric	Full Ht. Part No.
No. 8	2.36 mm	9423
No. 10	2 mm	9418
No. 12	1.7 mm	9424
No. 14	1.4 mm	9425
No. 16	1.18 mm	9152
No. 18	1 mm	9321
No. 20	850 µm	9153
No. 25	710 µm	9250
No. 30	600 µm	9154
No. 35	500 µm	9056
No. 40	425 µm	9016
No. 45	355 µm	9251
No. 50	300 µm	9142
No. 60	250 µm	9143
No. 70	212 µm	9252
No. 80	180 µm	9101
No. 100	150 µm	9186
No. 120	125 µm	9253
No. 140	106 µm	9015
No. 170	90 µm	9014
No. 200	75 µm	9003
No. 230	63 µm	9004
No. 270	53 µm	9102
No. 325	45 µm	9011
No. 400	38 µm	9133
No. 450	32 µm	9410
No. 500	25 µm	9202
No. 635	20 µm	9415

Overall Height: 1-3/4 in.

Depth to Cloth: 1-1/8 in.

Notes: All sieves 200 mm diameter

For use with Air Jet Sieving System 200 LS

Each sieve is supplied with a serial no. and a matching test sieve Certificate of Compliance

See page 35 for value added NIST Traceable Certification Services

Includes sealing ring



GET IN TOUCH

8570 Tyler Boulevard, Mentor,
Ohio 44060, USA
www.wstyler.com
1-800-321-6188