

VS1000

VariSifter™

Operation & Set-up Manual



Advantech Manufacturing, Inc. a W.S. Tyler Company

8570 Tyler Blvd, Mentor, OH 44060

T. 800-321-6188 • F. 440-974-0921

E Mail: info@wstyler.com • Web Site: www.wstyler.com

ADVANTECH
A wstyler® Company

Specifications

Thanks to the VariSifter's™ internal converter, a single model can be used in any of the following power environments:

- 120V/60Hz
- 120V/50Hz
- 240V/50Hz
- 240V/60Hz

Materials of Construction

Stainless Steel Test Table
Steel Cabinet and Frame
Baked Powder Finish Throughout
Acrylic Sieve Frames, Spacers, and Top Cone
Metal Column Lock
Aluminum Fines Collector Holder

Physical Dimensions

| | |
|-------------------------|-----------------------|
| Weight..... | 35 lb (16 kg) |
| Cabinet Dimensions..... | 23" h x 10" w x 12" d |
| | 61 cm x 25 cm x 31 cm |

Operating Conditions

This device will function properly at any non-condensing humidity level within the temperature limits of 0° to 120°F (18° to 49°C). However, for test repeatability, it is recommended the ambient temperature and humidity be controlled. The sieves and accessories used with this device should never be subjected to temperatures above +125°F (52°C) or below -45°F (-43°C).

External vibrations of a low energy level will have little effect upon the accuracy of the test results. For optimum results, the device should be operated on a stable, level surface. This practice will help ensure an even layer of particles on each sieve.

Operating Instructions

Installation

Place the VariSifter™ on a level surface for operation. Observe the ambient temperature and humidity guidelines outlined in the specifications section.

Electrical Connection

Plug the power cord into the socket in the rear of the unit and then into the power source. The VariSifter™ has an internal power converter to accommodate various power environments. (120V/50Hz, 120V/60Hz, 220V/50Hz, 220V/60Hz)

VariSifter™ Sonic Separator Control Panel

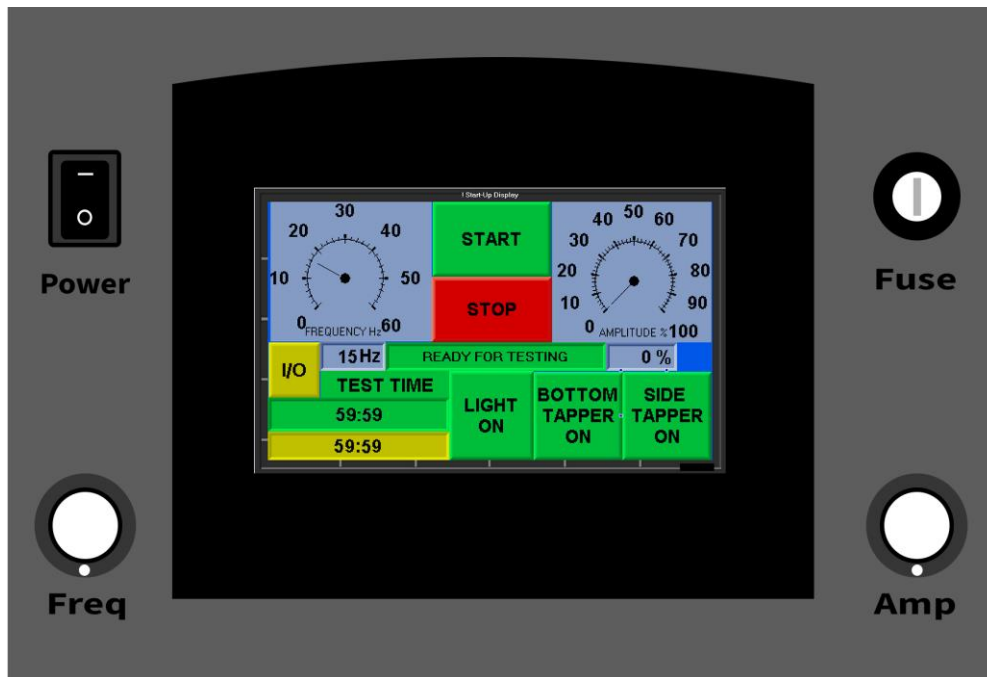

Frequency Control

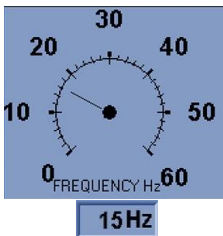

Frequency (Hz) of each test may be customized from 15Hz up to 60Hz by turning the Frequency knob (**Freq**) on the left side of the control panel. A read-out of the setting will display on the touch screen both in the analog expression and digitally. This setting will vary the number of "tries" per second the sample particles experience.

Start/Stop



After programming the desired test time, hit the **START** button to begin your test and the timer will begin to count down. The **STOP** button will interrupt the test, but retain the remaining test time on the countdown. To completely abort a test and reset the timer, press and hold the **STOP** button for two seconds.

Amplitude Control

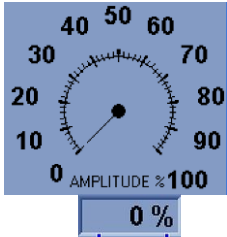

Amplitude is adjustable from 0 - 100 by turning the Amplitude knob (**Amp**) on the right side of the control panel. The read-out (expressed as a percentage of power) shows both in analog and digitally. The amplitude will vary the intensity of the sound wave used thereby adjusting the amount of "lift" applied to particles in the test stack. The optimum amplitude for the sample will depend upon the density of the particles, static electric charges, agglomeration, etc. Observing the sample during setting the amplitude is key in achieving the optimum amplitude for any given test. The ideal amplitude has been achieved when the heaviest particles are rolling on the sieve surface and no particles are arcing higher than half the height of the sieve surface.

Manual I/O Testing Screen



The **I/O** screen is a troubleshooting module that will be helpful in the event of malfunctions. Advantech/W.S. Tyler telephone or email support can assist with walking through the Manual I/O Testing Screen buttons, if necessary.

Machine Status Indicator



READY FOR TESTING

- **"READY FOR TESTING"** – Displays when the test stack is properly in position
- **"TEST STACK NOT IN POSITION"** – If the test stack kicks out of position a long series of beeps will be emitted and sifting and tapping will be interrupted
- **"TEST STACK SECURE"** – When the test stack is properly in place, testing is ready to proceed
- **"TEST IN PROGRESS"** – Indicates the test is currently running
- **"TEST COMPLETE"** – The machine will emit 4 beeps when testing is complete
- **"RUN ABORTED"** – If the **STOP** button has been held for two seconds, a series of 4 beeps will sound and the timer will reset
- **"HMI BATTERY LOW"** – When this message is displayed, please contact your W.S. Tyler representative for instructions for maintenance.

Timer



The maximum test run-time is 59 minutes and 59 seconds. To program the test run time, touch the green button below the "TEST TIME" box.

Program the minutes and seconds for your test, then touch the enter key.



The test time length will display in green under the "TEST TIME" button. The time remaining is displayed below that in yellow.

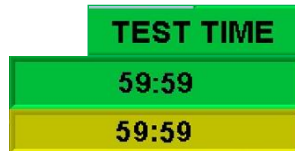

Light



The interior light may be turned on or off by tapping the "LIGHT" button.

Vertical and Horizontal Tappers



The tapping mechanisms on the VariSifter™ assist in reorienting particles on the sieve surface and breaking up agglomerates. Each may be independently turned on or off, per user preference. The respective buttons will be green if the function is on and grey if the function has been turned off.

NOTE: When sifting powders 45µm and finer, addition of the horizontal tappers may be beneficial. Use of the vertical and/or horizontal tappers may not necessarily help with static electric charge issues.

Removing the Stack Assembly

The stack assembly can be removed from the test chamber by first removing the Column Stop in front of the test stack. Grasp the locking arms on the column lock assembly and pull straight down while squeezing the arms together. This will lock the assembly together so the stack can be slid straight out of the test chamber. **WARNING:** Do not leave the column lock arms clamped while the test stack is out of

the test chamber. To avoid possible stack upset, unclamp the arms immediately upon removal from the machine.

Disassembling the Stack Assembly

While steadying the stack with one hand, spread the column locking arms with the other hand by sliding a thumb and forefinger into the openings between the lowest sieve and the column locking. The spring-loaded column lock will release. It can then be carefully removed and access gained to the rest of the stack components.

Selecting the Sieves for Analysis

Select the sieves required for analysis. The height of the testing stack used within the VariSifter™ is a fixed height.

U.S. Standard Sieve Series – 5/8" overall height

A maximum of six U.S. standard series sieves (sieve sizes #3.5 through #635) may be used at one time. Any combination of sieves, accessories, or spacers making up the standard stack height of six standard sieve units may be used.

Precision Electroformed Sieve Series – 1-1/4" overall height

A maximum of three precision electroformed sieves may be used at one time. Any combination of sieves, accessories, or spacers making up the standard stack height equivalent to three precision electroformed sieves may be used. When performing separations 30µm or finer, use only **one** precision sieve at a time.

Preparation for the Analysis

To prepare for the analysis of a sample for the first time, it will be necessary to perform a few simple tasks:

Gather the Ancillary Equipment Needed:

- Weighing device (balance or scale with resolution in grams suitable for your application; generally, 0.1g or 1.01g are sufficient) 100g capacity is suitable.
- Small, natural hair brush for brushing fine particles from the standard sieves wire cloth or precision mesh **frames**. (NOTE: Brush sieves from the underside ONLY! Never force material through a sieve opening. **Never brush precision mesh.**)
- Means of recording and calculating tare weights, sample weights, percentages, etc.

Note: In addition, prior to performing the first test, all sieve, standard spacers, and the top cone should be washed according to the care section that follows. This step will reduce the chance of sample contamination from any residues left over from the manufacturing process.

Performing the Analysis

The following steps constitute a typical analysis with the VariSifter™ Sonic Separator:

Weighing the Parts

Weigh and record the tare weights of the diaphragm, top cone, spacers, sieves, and fines collector.

Installing the Fines Collector

Install the fines collector in the fines collector holder. Fasten the round metal plate at the bottom of the fines collector to the fines collector holder by sliding the keyhole slot in the fines collector over the fastener mounted in the fines collector holder base.

Assembling the Sieve Stack

Assemble the sieve stack with the coarsest sieve on the top of the stack and finest sieve at the bottom. If fewer than six (6) standard series or three (3) precision electroformed sieves are used, add spacers to the **top** of the stack to fill out the proper stack height as described in the *Selecting the Sieves for Analysis* section above.

Introducing the Powder

Discussion of the proper methods of extracting gross samples and preparing test samples for analysis is far too complex to be dealt with here. For more information on sample extraction and preparation, please refer to the publication, *Test Sieving: Principles and Procedures*, toward the back of this manual.

A good rule of thumb is to use the smallest sample size possible that is still representative of the lot from which it was extracted. Sample sizes of 1 gram are a good starting point for VariSifter™ determinations. The sample size can be increased until the optimal combination of sample size, time, sift amplitude and frequency are determined.

Select a proper mass of powder to be tested. When sieving materials larger than 38 µm; do not exceed 20g. When sieving materials smaller than 38µm, do not exceed 10g. Weigh and record the mass of the powder sample. Place the powder sample on the top sieve in the stack.

Installing the Diaphragm

Place the diaphragm on top cone with the metal ring protruding downward. When properly orientated, the word "**TOP**" will show on the latex material.

Replacing the Column Lock

WARNING: Do not lock column lock arms until you are ready to place the test stack into the test chamber! Uncontrolled release of the arms could cause stack upset and sample loss. Place the column lock onto the sieve stack and press straight down until the locking arms snap onto the fines collector holder.

Check the Control Panel

As a safeguard, make sure the amplitude control is set at "0" before placing the stack assembly into the test chamber. This is necessary to prevent damage to the sieves and the test sample in the chamber. If the amplitude had been inadvertently set to the maximum setting or the timer interrupted mid-cycle, for example, the sudden impact of the signal from the speaker driver could damage the sieves or compromise your test sample.

Inserting the Stack Assembly

Slide the stack assembly into the test chamber with the column arms locked. The stack assembly is stopped at the top by two tabs on the driver support plate above. On the test chamber table, you will notice two rivets that limit how far the stack can be placed inside the chamber. The table switch on the left side of the test platform is a safety interlock device that prevents the unit from operating if the stack moves out of position. This switch will be properly deployed and the circuit activated if the stack is inserted correctly.

Once the stack assembly is in position, the column lock can be released by sliding a thumb and forefinger into the openings between the lowest sieve or spacer and the column locking arms. Spread the column locking arms. The spring-loaded column lock will release and expand to lock the column into the test chamber, forming a tight seal.

Place the L3-N9 Column Stop in front of the test stack. This column stop ensures the stack will remain in place during testing.

Close the sliding door to the test chamber.

Beginning the Test

Program the predetermined testing time and frequency per the instructions in the Control Panel section above. Choose whether to activate your bottom and side tappers. While virtually all test procedures benefit from the use of the vertical tap, some may not. Use the setting appropriate to your samples. Refer to the "Vertical and Horizontal Tappers" section in the Control Panel section for more information.

Setting the Amplitude

Note: The amplitude is the "lift" action on the particles as the oscillating sonic column is set in motion. The higher the amplitude

setting, the more “lift” on particles. Moving the particles more vigorously than necessary **DOES NOT** increase the speed or precision of the separation. In fact, excessive amplitude settings may increase electrostatic problems, sample loss, and equipment wear.

WARNING: *Due to the extremely fragile nature of the Precision Electroformed Series sieves, excessive amplitude, especially over extended periods of time can cause immediate or premature sieve failure.*

After starting the timer, increase the amplitude **SLOWLY** until the largest particles begin rolling on the top sieve. The entire operation can be viewed through the sidewalls of the sieves. The finer material should begin flowing through the sieves within seconds. Note that no particles should be arcing higher than half the height of the sieve.

Completing the Test

For an initial test run: When no more material can be seen falling through the sieves, note time elapsed. For detailed instructions on determination of optimal test time, please see Chapter Six “Performing the Sieve Analysis” of *Test Sieving: Principles and Procedures*. The section titled “Recommended Time Intervals” will be helpful.

For a routine test run: When the timer counts down to “0”, open the door and follow the procedures listed for ‘Removing the Stack Assembly’. Caution should be exercised when dismantling the stack assembly to avoid loss of sample retained on the sieves or in the fines collector.

The parts can be weighed directly on the weighing device, removing the need to transfer the material to a weighing dish (thus reducing potential sample loss). Don’t forget to weigh the fines collector as well. Record the weights on the worksheet used to record the tare weights. Subtracting the tare weight from the post-test weight yields the mass of the sample retained on the part. The percentage retained at each sieve size can be calculated simply by comparing the weight on each part with the starting sample weight.

CARE OF VARISIFTER™ SONIC SEPARATOR AND ACCESSORIES

The Model VS1000 VariSifter™ and Accessories will perform satisfactorily for many years if the following basic care instructions are observed:

Cleaning the Sieves and Stack Assembly Parts

For best results, stack assembly components and sieves should be cleaned in an ultrasonic cleaner of 150 watts or less. General cleaning is best accomplished in a mild solution of dishwashing detergent and water maintained at 75-80°F (24-27° Celsius). Ultrasonic cleaning has

proven to be the most effective method of removing particles plugging woven wire cloth sieve openings. Regular ultrasonic cleaning will help prevent particle buildup in the sieve openings, thus reducing the amount of time each sieve must be exposed to ultrasonic vibrations. Care must be taken in how long the sieves are exposed to the ultrasonic vibrations, as damage can result from overexposure. Do NOT ultrasonically clean precision sieves.

After washing, rinse the parts with tap water, and allow to air dry. DO NOT expose the sieves, spacers, or top cone to heat sources of any kind. Heat sources will cause warping and/or cracking of the parts which will compromise the airtight seal between the stack assembly parts during use. If an ultrasonic cleaner is not available, immerse items to be cleaned in the same mild detergent solution, rinse and allow to air dry as directed. **Precision (electroformed) test sieves have very specific warnings and care procedures. Please refer to the Handling and Use Instructions on the jewel case.**

CAUTIONS

U.S. Standard Sieve Series: Improper handling can cause serious damage to the sieve openings and accelerate sieve failure.

- **DO NOT** remove particles clogging sieve openings with a needle or other sharp object.
- **DO NOT** use compressed air to clean the sieves or dislodge trapped particles.

Precision Electroformed Sieve Series: Store the precision electroformed sieves in the protective jewel case provided and follow the Handling and Use Instructions on the box.

- **DO NOT** remove particles clogging sieve openings with a needle or other sharp object.
- **DO NOT** brush the electroformed media.
- **DO NOT** touch the electroformed media with your fingers. Natural acids and oils in the skin will attack and discolor the fragile electroformed mesh and cause permanent failure.
- **DO NOT** ultrasonically clean precision electroformed sieves.

Cleaning the Fines Collector and Diaphragm

The fines collector and diaphragm are made of durable latex material. With regular care, these parts can withstand a considerable number of duty cycles. Both parts can be cleaned in a mild detergent and water solution and rinsed with water. The parts should be allowed to air dry, avoiding heat and sunlight.

After drying, both parts should be dusted lightly with talcum powder (NYTAL 200 or any commercial unscented talcum powder). The excess talcum powder can be blown off with low-pressure compressed air. Return the parts to their protective envelopes for storage, as light and some chemicals in the air can be harmful to the latex, causing holes and cracks to appear prematurely.

Users' Tip: For longer life of the fines collectors, rotate the use of several collectors over time. For example, use fines collector #1 on Monday, wash and store the collector at the end of the day and use collector #2 on Tuesday, etc. Set up a regimen to rotate 3-5 collectors over the course of a week, or whatever your usage requires. Allowing the latex to 'rest' before it is put back into regular service can significantly extend the life of the individual collector.

Cleaning and Care of the VariSifter™ Sonic Separator Unit

The VariSifter™ cabinet, test chamber and aluminum stack assembly parts should be wiped off periodically with a soft, damp cloth.

Servicing the VariSifter™ Sonic Separator Unit

Only personnel qualified by Advantech/W.S. Tyler should service the VariSifter. If any performance or operational problems arise, please contact Advantech/W.S. Tyler directly.

VARISIFTER™ LIMITED WARRANTY

Advantech/W.S. Tyler guarantees all its apparatus against defective material and workmanship for a period of one year from the date of delivery. This guarantee is limited to repair or replacement of the defective apparatus in our factory in Mentor, OH. Advantech/W.S. Tyler does not assume responsibility or accept invoices for unauthorized repairs to its apparatus. Under no circumstances shall Advantech/W.S. Tyler be liable for loss of profits or other damages.

Advantech/W.S. Tyler is not responsible for damage to apparatus due to improper installation or operation beyond its rated capacity (intentional or otherwise). It is distinctly understood that the above covers all conditions under which Advantech/W.S. Tyler apparatus are sold.

For warranty claims or other service requests, please obtain return authorization prior to shipment by contacting:

W.S. Tyler

8570 Tyler Blvd, Mentor, OH 44060
T. 800-321-6188 | F. 440-974-0921
E Mail: info@wstyler.com
Web Site: www.wstyler.com

Test Sieving: Principles and Procedures

A Discussion of the Uses, Capabilities, and Limitations of Testing Sieves as Analytical Tools



Foreword

Through ASTM and many industry organizations, standards have been established for particle size for powder, granular and larger sized materials. This manual has been prepared to help guide users of test sieves through the proper procedures as well as provide many additional tips that can enhance the existing procedures.

Our aim is to provide assistance to both the experienced and non-experienced particle technologist in developing comprehensive particle size test results, reduce test variations and enable the user to isolate and identify sources of error or variations in the data.

If additional help is desired in establishing your sieve analysis procedure, or if you desire a list of suppliers of the equipment highlighted in this manual, please contact W.S. Tyler, 8570 Tyler Blvd, Mentor, OH 44060

Table of Contents

| | |
|--------------------|--------------------------------------|
| CHAPTER 1 - | WHAT IS SIEVING? |
| CHAPTER 2 - | ... USES, LIMITATIONS AND ADVANTAGES |
| CHAPTER 3 - | .. WORKING GLOSSARY OF SIEVING TERMS |
| CHAPTER 4 - | SIEVE SPECIFICATIONS |
| CHAPTER 5 - | SIEVE CALIBRATION PROCEDURES |
| CHAPTER 6 - | PERFORMING THE SIEVE ANALYSIS |
| CHAPTER 7 - | SIEVE CARE AND CLEANING |

CHAPTER 1

WHAT IS SIEVING?

A simplistic definition of sieving is the separation of fine material from coarse material by means of a meshed or perforated vessel. Professor Terence Allen characterizes sieving as "The aperture of a sieve may be regarded as a series of gauges which reject or pass particles as they are presented to the aperture." ⁽¹⁾ This theory was actually in practice during the early Egyptian era as grains were sized with 'sieves' of woven reeds and grasses.

The level of sophistication increased with the rise of the industrial revolution and the need for more sophisticated methods for classifying material by their particle size. As requirements for sized material rose, technology in producing uniform sieving media increased. Woven wire cloth was introduced as an alternative, providing greater accuracy and durability. At present, this woven cloth is available in a range of sizes from 125 mm (5") openings to 20 micrometer openings.

All mesh sizes are covered by both national and international standards.

The need for particle size analysis in the finer size ranges (i.e. 38 micrometers and less) prompted the development of the electrodeposited sieve. These sieves, sometimes called electroformed or micromesh, are currently being produced with openings as fine as 3 micrometers. The mesh openings are extremely uniform in both size and shape and maintain exacting tolerances.

While the technology related to sieve analysis has come a long way since the reed sieves of ancient Egypt, few new developments have come along since the 1940's. Professor Kurt Leschonski wrote "Sieve analysis is one of the few methods of particle size analysis which has escaped modernization." ⁽²⁾ While the modernization has not come in the actual hardware of sieving, refinements in the application and utilization of existing equipment has proceeded.

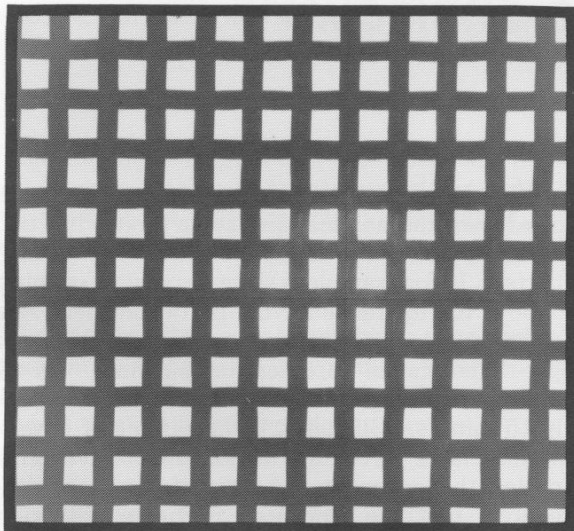

WOVEN SIEVE CLOTH

Variations in opening size and shape are common.

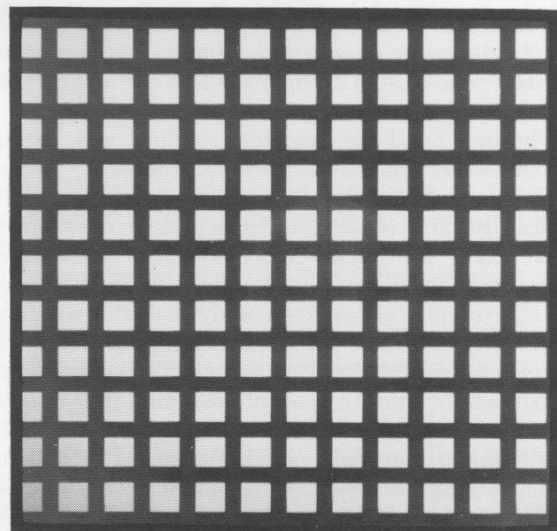

ELECTROFORMED SIEVE CLOTH

Electrodeposited material showing uniformity in opening size and shape.

CHAPTER 2

USES, LIMITATIONS AND ADVANTAGES

Harold Heywood wrote "I often refer to sieving as the 'Cinderella' of particle size analysis methods; it does most of the hard work and gets little consideration."⁽³⁾

There are numerous reasons for the selection of high quality testing sieves as a first choice in particle size analysis work. Leschonski said "... because of its simplicity - everyone immediately understands the purpose of a stack of sieves and its operation -and its inexpensive- ness."⁽⁴⁾ Standard sieve analysis is probably the fastest and most widely used quality control procedure in any powder process control industry. Used frequently as a mediating device between the production and sales divisions of a process corporation or between the sales force and the customer, test sieve analysis work enjoys the universal recognition of being the best 'quick and dirty' test procedure for rapid particle size distribution data. The outcome of the analysis is easily calculated and interpreted for comparison between laboratories. Start-up cost to institute a basic sieving quality control program is minimal, and operators at most levels of training are capable of performing a successful sieve analysis. With these factors in mind, it is easy to see why testing sieves are as ubiquitous as they are in industry. Materials from crushed ore chunks of over 114.3 mm (4 ½") in diameter to slurred alumina and porcelain powders of less than 20 micrometers are all analyzed with test sieves on a regular basis.

Whether hand or machine sieving, wet or dry preparations, analysis or production work, testing sieves have found a niche in the quality control laboratory. Given this overall acceptance of test sieves as a viable analytical device and the widespread presence of the sieve in laboratories of all industries, any shortcomings of such an analytical device would be magnified. For all of the advantages available to the test sieve user, limitations must be recognized

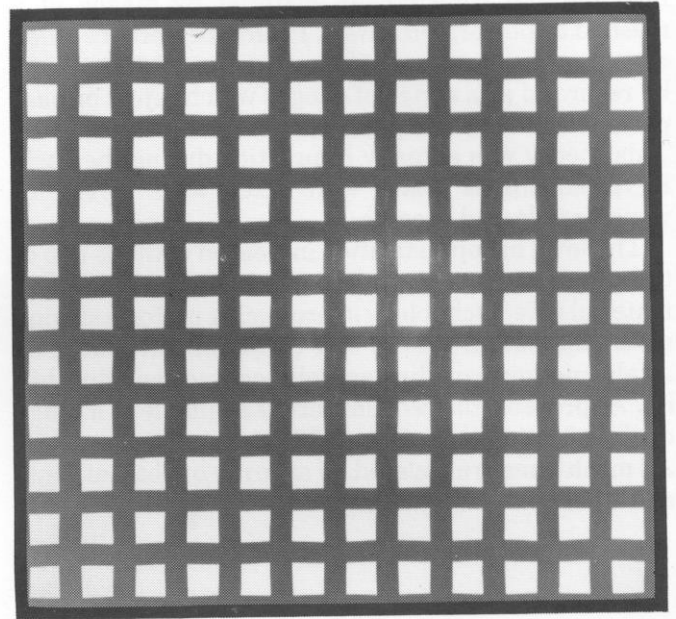

CLOTH WITH WIDE MESH VARIATIONS

Alternating areas of narrow and wide mesh openings can significantly change sieve analysis results.

and accounted for in the presentation and analysis data.

Test sieves are individuals. Being fabricated of a woven mesh material, variations in the weave are common. The chances of locating two sieves with an identical distribution of opening sizes are extremely remote. Due to these variations, the reproducibility of test results between sieves can be adversely affected. The stringent standards imposed by ASTM, ISO or other regulating bodies have established tolerance factors which allow for the permissible variations in the weave while striving to maintain a level of uniformity in the performance of the 'test grade' sieve cloth. (See Table 1)

With this variation of opening sizes present, some smaller than the nominal and some larger, the time interval of the sieve analysis becomes extremely important. If, for example, a sieve has several openings far above the nominal opening size for the particular mesh size,

and the test is run for 30 minutes, the probability of larger-than-nominal particles finding those oversized openings is much greater than if the test was run for only 15 minutes. Similarly, if the sample of powder contains a large percentage of elongated or needle like particles, a longer test interval would provide a greater likelihood that the elongated particles will orient themselves 'on end' and pass through the openings. If the sieving cloth has a wide range of opening sizes, the sieving of this type of material has a compounded error.

Another factor which must be considered is the reaction of the material to ambient conditions. The most accurate test sieve available would be of minimal use if the relative humidity in the test lab was 99%. Extremely dry conditions can cause fine powders to adhere to the sieve

components and each other with strong electrostatic charges. Additional types of sieving problems are discussed in the glossary section.

To minimize error caused by wire cloth variation, steps must be taken at every stage of fabrication that will assure the uniformity of the woven mesh as well as the compliance with the applicable standards. Both the weaver and the test sieve manufacturer must maintain a constant monitoring program measuring the actual opening sizes of the wire cloth as well as the uniformity of those openings. The loss to the manufacturers in rejected out of specification sieve cloth is a gain to the end-user in uniformity and compliance.



COMPARATOR

Profile projector specially designed and built for wire cloth and sieve inspection.

CHAPTER 3

GLOSSARY OF SIEVING TERMINOLOGY

Sieving terminology is frequently used and abused in writing specifications for materials. Listed below are some of the most frequently used terms and a general discussion of their meaning:

Agglomerate: natural tendency of materials to clump or ball together. This condition is very common in materials with high moisture, fat or oil content or those with fibrous or extremely irregular topography.

Blinding: plugging of the screen openings with particles either exactly the same size as the sieve opening or by fine particles

which build up on the wire mesh and eventually close off the openings. Frequently referred to as pegging. (Photo Page 4)

Cover: stamped or spun lid that tightly covers the top of a sieve to prevent the loss of the material sample during sifting or mechanical agitation.

Electrostatic charges: accumulation of electrical charges on the particles and sieve components causing clinging, agglomeration or blinding. This condition is frequently seen in hydrocarbon-based materials, plastics, reactive metals, paint pigments and powders with a large fraction finer than 20 micrometers.

Extended rim pan: a sieving pan with a skirt designed to nest within a sieve stack, allowing multiple tests to be performed simultaneously. Frequently called a nesting pan or spacer.

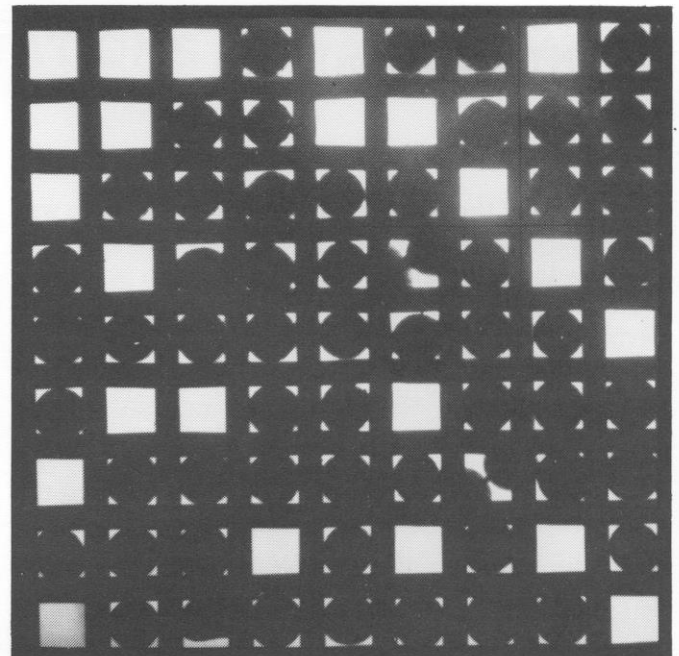
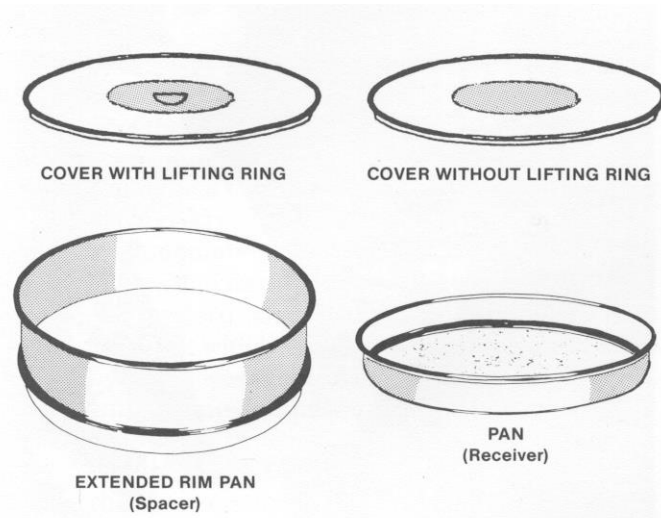
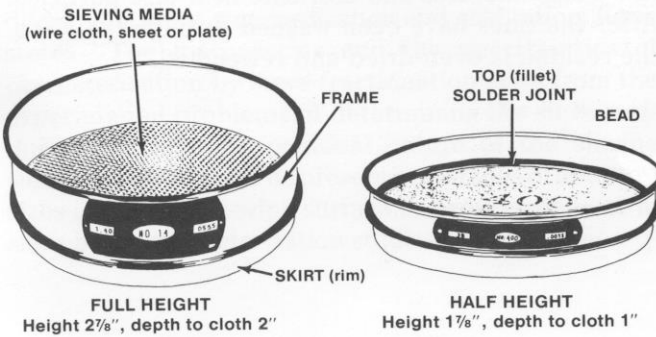

BLINDED SIEVE

Spherical and near-size particles can blind or peg in the sieve openings.

Flow additive: powdered substance added to the sample to reduce agglomeration, neutralize static charges and improve the flow characteristics of the sample. Common additives are fine silica, activated charcoal, talc, and other commercially produced natural or synthetic substances. Generally, the additive is pre- screened to a known average particle size, blended with the sample (approximately 1% additive by weight) and then screened with the additives value removed from the reported data.

Frame: a rigid sidewall used to form the body of the testing sieve. Common depths are 50.8 mm (2" full height) for 8" sieves and 25.4 mm (1" half height). Special application sieves of other depths are also in use.

Mesh: screening medium with openings of uniform size and shape made of woven, punched or electrodeposited material.

Pan: stamped or spun receiver of materials passing through the finest sieve.

Skirt: section of test sieve below the sieve mesh that allows for mating or nesting of the sieves in a test stack.

Support mesh: coarse sieve cloth mounted under fine sieve cloth in a test sieve to provide extra strength. This is widely used in wet sieving operations to protect the fragile fine sieve cloth. Frequently called backing cloth or rolled backing cloth.

Test Sieve: screening medium (mesh) with openings of uniform size and shape mounted on a rigid frame, usually for laboratory testing or small scale production applications. The frames can be made of various materials, the most common of which are brass and stainless steel in a cylindrical configuration, having a diameter of 3", 5", 6", 8", 10", 12" or larger.

Wet sieving: the separation of fines from the coarse portion of a sample while suspended in an aqueous solution introduced to a testing sieve. The liquid medium is used to negate static charges, break down agglomerates and lubricate near-size particles. After the fines have been washed through the sieve, the residue is oven-dried and re-weighed.

CHAPTER 4

SIEVE SPECIFICATIONS

-Domestic and International

The U.S. Standard Sieve Series is a metric system based series first suggested by the American Society for Testing and Materials in 1913. The opening sizes in this sieve series are in the ratio of the fourth root of two. This numerical relationship was first suggested by Professor P .R. Rittinger, a German researcher, in 1867.

In the fourth root of two series, every opening size is 1.189 times the opening size of the next smaller sieve. This

relationship continues into sieve opening area measurement. The U. S. Sieve Series provides that the area of each sieve opening size is 1 1/2 times the area of the preceding sieve size.

By using every other sieve in this number series, the relationship becomes based on the square root of two (1.414), with the area of the opening being twice that of the preceding sieve size. Thus, by skipping two sizes, you create an area ratio

of 3 to 1, or by skipping three sizes, you create a ratio of 4 to 1.

When selecting sieves from this series, any number of sieves can be used for an analysis. Care must be taken in selecting each sieve between two points, every other sieve, every fourth sieve, etc., to keep within the mathematical progression of the series.

After World War II, the International Standards Organization (ISO) was formed in an attempt to establish world standards. Though the U.S. Sieve Series had proven to be effective and was in use throughout the world, members of the ISO would not accept the U.S. Sieve Series as a world standard. The ISO chose to adopt the Preferred Number Series based on the roots of ten. The Preferred Number Series

was suggested by Charles Renard of France in 1879. His system is based on the tenth, twentieth and fortieth roots of ten (designated R-10, R-20 and R-40). See Table 2.

A compromise was reached between the ISO and the proponents of the U.S. Sieve Series when it was discovered that every third value in the R-40/3 table is in a step ratio of 1.1885, sufficiently close to the fourth root of two (1.1892) used in the U.S. Sieve Series. In 1970, slight adjustments were made in the U.S. Sieve Series to align the series perfectly with the ISO specifications.

Copies of these tables of specifications can be found in Table 3.

CHAPTER 5

SIEVE CALIBRATION PROCEDURES

Quantifying and accounting for variations in test sieve results have become two of the most important topics in particle technology today. Once again, the ubiquitous nature of stacks of test sieves in powder labs around the world has contributed to the scope of the dilemma in sieve standardization and calibration. Kaye states "The inaccuracies and the uncertainties of characterization by sieve fractionation arise from the experimental problems of determining the sieve residues and from the non-ideal nature of the sieving surfaces." Further, "The presence of a range of aperture sizes in any real sieving surface is a source of error in sieve based characterization studies since the theoretical or nominal size of the sieve is taken to be the boundary limit for the sieve residue." ⁽⁵⁾

Not only is the test sieve user plagued with variations in the weave of the cloth, but also confronted with the effects of

particle shape on sieving results. Nearly 50 years ago, A.M. Gaudin wrote, "Powders with identical size distributions, densities and chemical composition may behave quite differently as a result of variations in particle shape between samples. For example, powders consisting solely of spherical particles are likely to have good flow properties, while powders containing needlelike particles will not." Further, "In addition, it is impossible to isolate the concepts of particle size and shape, since the method of size measurement will influence the particle size which is determined." (6)

Numerous approaches have been tried to compensate for the effects of variations in wire cloth and particle shape. The methods have fallen into 3 basic categories: 1) inspection of the mesh to determine opening size, 2) material testing of the sieves to determine if sieves fall within performance specifications, and 3) a

combination of methods 1 and 2, assuring compliance with both opening size and performance specifications.

Probably the most elementary of the inspection methods is the use of the etched glass slide. This procedure relies on what is referred to as the 'Moire Effect', which compares the number of wires per inch in the wire cloth sample to the number of lines per inch etched on the glass slide. By microscopically measuring the wire diameters, a rough estimate of the opening size can be approximated. One major short-coming of this procedure is the assumption that all wire diameters within the sample are the same. A slight variation in wire diameter can translate to a significant change in opening size.

An alternative to this measurement approach is the use of a high-powered optical comparator or profile projector. In this method, powerful light sources illuminate the mesh from both above and below and project the image onto a glass screen. Calibrated micrometer stages move the mesh sample in relation to a reference point allowing measurements with an accuracy of 1 micrometer to be made on both the opening and wire diameter. The results are displayed on a numerical readout. The broad field of view of the comparator allows for the scanning of a large number of sieve openings, facilitating a more comprehensive picture of the nature of the sieve cloth.

In the material testing of sieves, powder samples are run on subject sieves and the residue calculated. These values are then compared with other sieves in selecting what are often referred to as 'matched' sieves. There are a number of shortcomings in this procedure also. The first and foremost problem encountered is that of compliance. Conceivably, it is possible to find hundreds of sieves that will provide the same performance data when tested with a reference material and still not meet ASTM standards.

While the sieves perform comparably, they do not meet the basic criteria of ASTM

specifications, which should disqualify them from use as a U.S. Standard Testing sieve. Another problem encountered with material matching is the use of reference samples that are different in shape, size or density than the users' products. For example, a manufacturer of spherical steel shot would yield significantly different results on a sieve that had been matched with an angular ground silica material. In this case, both shape and density are considerably different. The key to proper matching is using the end-users own product or a material that approximates the product most closely.

The final approach is a combination of the first two methods. First, the sieve is inspected optically for compliance with all applicable standards. Openings and wire diameters are measured, not averaged. After the sieve opening distribution has been characterized and evaluated, actual material testing can begin. During the material testing, samples of the user's product are used for the standardization procedure. All tests are run for repeatability and the variation between test results calculated. This procedure yields a testing sieve with known values in the two most essential parameters compliance with specifications and performance under duplicate test conditions.

An alternative that has been used with some success is the use of correction factors between sieves. Once a 'master set' of sieves has been established, a reference sample is tested on the stack. The values are calculated and retained. As new sieves are acquired, the original reference sample is tested on the new set and the values calculated. Any variations between the sieve stacks can be compensated for with correction factors or multipliers. For example, a sieve in stack 3 may retain more or less than the comparable sieve in the master set. A multiplier of magnitude greater than or less than 1 is necessary to calculate the comparable retention value on that sieve when compared to the master set. In this way, every sieve in use can be compared to the master set to standardize

sieving results. Whatever method you use, it is essential that your starting point is based on ASTM specifications. This

compliance is necessary to assure uniformity between and within industries.

CHAPTER 6

PERFORMING THE SIEVE ANALYSIS

In obtaining meaningful sieve analysis data, six major steps are recommended. 1) Obtain a representative sample of the material to be evaluated. 2) Prepare the sample for evaluation; this may involve washing and/or drying the sample. 3) Reduce the sample to a size suitable for the sieve analysis procedure. 4) Perform the actual sieve analysis procedure. 5) Compute the data and convert the data into a usable format. 6) Organize the data and assemble the information for presentation.

Granular and powder materials are prone to segregation during movement and storage of the products. This segregation can be due to the disparity of the particle sizes and the varied densities for blended products. When forming a stockpile of material, the larger, coarser particles are heavier and tend to roll to the lowest portion and outer perimeter of the cone. The finer particles are lighter and more angular and remain concentrated at the top and through the vertical center of the cone. Obtaining samples from only the outer perimeter or from the top of the cone would not provide a sample which would be representative of the entire batch.

Sample extraction and preparation is the most commonly overlooked variable in sieve standardization programs. Testing bias can be added at many places along the progression from the raw materials received from a supplier, samples taken at each stage of production, sample reduction procedures and samples when the product is ready for shipment to the customer. The way the samples are extracted from the original bulk volume varies with the way the materials are received, produced or stored. The ideal sampling method is one which provides the most representative sample with the least amount of material required.

The following paragraphs were first published in the ASTM technical publication STP 447 A. The collaborative efforts of the authors have produced a section on sampling technique which will aid in obtaining representative test samples from larger test sources...⁽⁷⁾

Sampling from a chute or belt

Accuracy in sampling is obtained where material is flowing from a chute or belt conveyor. The ideal place to collect the sample is where the material drops from the chute or belt. If the material stream is small enough, use a pail or other suitable receptacle which can be swung completely across the flowing stream in a brief interval of time and with uniform movement. The sampling receptacle should not be allowed to overflow, because the overflow would tend to reject a higher proportion of the larger particles that exist in a representative sample. Mechanical sampling devices are available for selecting samples automatically from a stream at uniform time intervals.

Sampling from carload shipments of coarse bulk material

For coarse materials, such as crushed stone and gravel, shipped in railroad cars, a recommended method is to dig three or more trenches at least 30.48 cm (1 foot) deep and approximately 30.48 cm (1 foot) wide at the bottom. Equal portions are taken at seven equally spaced points along the bottom of the trench by pushing a shovel downward into the material and not by scraping horizontally. Samples from trucks, barges, or boats should be taken in the same manner as from railroad cars, except that the number of trenches should be adjusted to the size of the transportation unit and tonnage involved.

Sampling from carload shipments of fine bulk materials

One established method for sampling a carload of bulk granular material is to take eight equal samples, (approximately 700 to 1000 grams each) from the bottom of a 30.48 cm (1 foot)) conical excavation. Samples should be suitably spaced to represent the length and width of the car and then combined into a single gross sample.

Sampling bulk shipments of fine material with a sampling tube

An alternate and simpler method of sampling a carload, or other bulk quantity of fine or granular material is by use of a sampling tube which, for this purpose, should be 38.1 mm (1 1/2 inches) by approximately 1.829 m (6 feet). Five or six insertions of the tube will produce approximately, a 2 pound (907g) sample.

Sampling from a carload of bagged material

One method of sampling a carload of material shipped in bags is to select, at random, a number of bags equal to the cube root of the total number of bags in the car and to take suitable portions (800 to 1000 grams for minus 6 mm material) from each of the selected bags for a combined gross sample.

Sampling from a pile

In sampling from a pile, particularly material like crushed stone or coal containing large particles, it is extremely difficult to secure samples that are truly representative. At the apex of a conical pile, the proportion of fines will be greater, while at the base; the percentage of coarse particles will be greater. Therefore, neither location will be representative of the whole. In a shoveling process, every fifth or tenth shovel, etc., should be taken depending on the amount of the sample desired. The sample should consist of small quantities taken at random from as many parts of the pile as are accessible and taken in a

manner that the composite will have the same grading as the larger amount.

Reduction of gross sample to test size for sieve analysis

After the gross sample has been properly obtained, the next step is to reduce it to a suitable size for sieve analysis without impairing in any way the particle size distribution characteristics of the original sample. This phase of the operation should follow the applicable procedures described in the succeeding sections and should be performed with as much care as was used in the collection of the gross sample and in performing the sieve test.

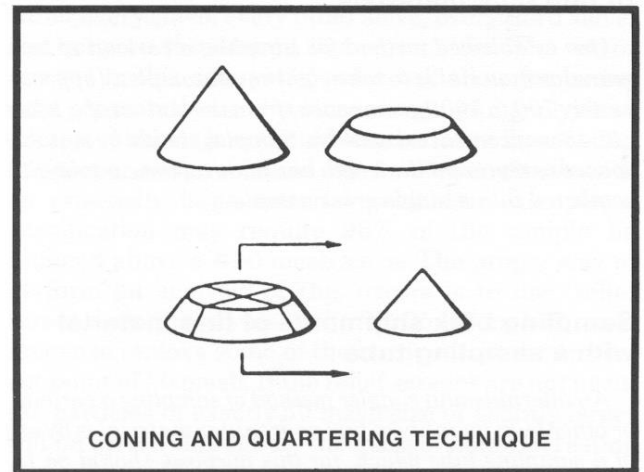

Coning and quartering

Pile the gross sample in a cone, place each shovel full at the apex of the cone, and allow it to run down equally in all directions. This will mix the sample. Then spread the sample in a circle and walk around the pile, gradually widening the circle with a shovel until the material is spread to a uniform thickness.

Mark the flat pile into quarters, and reject two opposite quarters. Mix again into a conical pile, taking alternate shovel-fulls from the two quarters saved. Continue the process of piling, flattening, and rejecting two quarters until the sample is reduced to the required size.

Sample splitters and reducers

Gross samples, if not too large, may be reduced to test sample size by one or more passes through a sample splitter or Jones type riffle, which will divide a sample in half while maintaining the particle size distribution of the original sample. By repeated passes, the sample can be split into quarters, eighths, and so on until the size of the sample desired is obtained. For larger gross samples, sample reducers are available which will select a representative 1/16 part with a single pass. After just two passes through such a unit, a representative one pound sample can be obtained from an original 256 pounds. Three passes will give a one pound sample from two tons of material. Always make sure that the passages in the splitter or reducer are at least three times the size of the largest particle in the sample. Do not attempt to arrive at exactly the amount of material specified for the test. If a 50 gram sample is desired, arrive as near to this amount as practicable, because it will make no difference in the test percentage results whether the sample is slightly larger or smaller. In attempting to arrive at an exact weight, the tendency is to discriminate by the removal of sizes that are not representative of the whole, thus destroying the representative quality of the sample.

Size of Sample in the Test

There is a natural tendency, although incorrect, to use an excessively large sample in the test. In most cases, a smaller sample will provide a more accurate analysis. Beware, however, that the more you split, the greater the chance of error. Testing sieves are a go or no go gauge; if the sample is too large it will not permit each of the particles an opportunity to present themselves to the screen surface. Often the limiting factor for reducing the sample size is the accuracy of the weighing device used to determine the amount of material retained on the sieve.

Generally a 25 to 100 gram sample is recommended. However, if it is necessary to establish the correct sample size, utilize the following procedure: Using a sample splitter, reduce samples to weights (i.e. 25, 50, 100, 200 grams). Analyze these

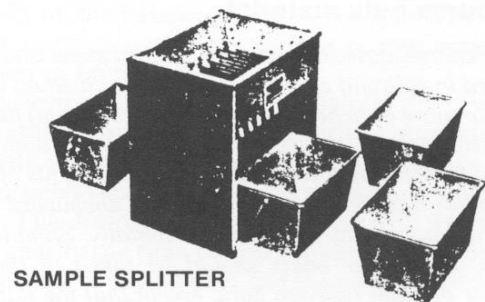
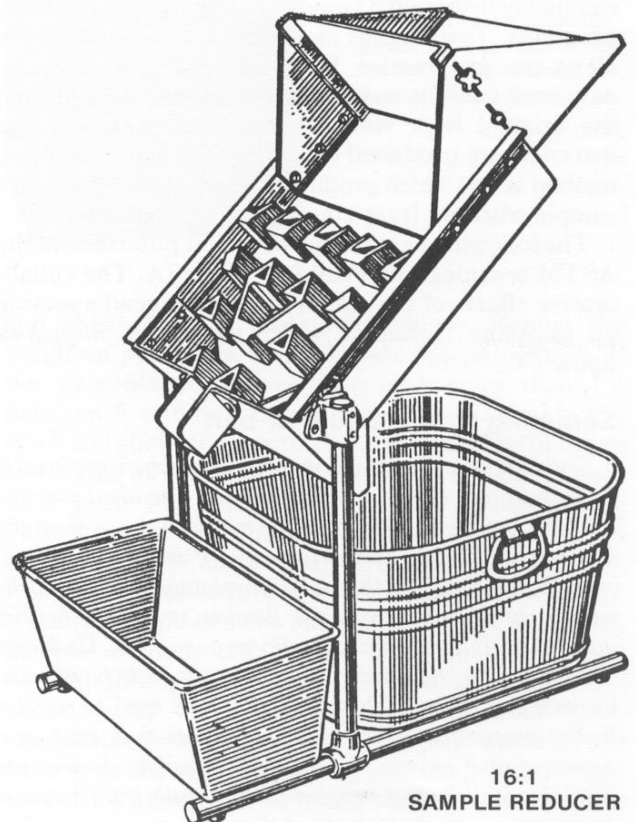

various sample sizes on a selected nest of sieves for a period of five minutes preferably using a mechanical sieve shaker. If the test with the 100 gram sample shows approximately the same percentage passing the finest sieve as the 50 gram sample, whereas the 200 gram sample shows a lower percentage, this would indicate that the 200 gram sample is too large and the 100 gram samples would be satisfactory. Then run the 100 gram sample on the same set of sieves for the same time period to see if repetitive results are obtainable.

A useful table of recommended sample sizes for tests with 200 mm or 8" diameter sieves is presented in Table 4. Note that the table gives sample sizes listed by volume. Recommended sample weights in grams can be determined by multiplying the values in Column 3 and 4 by the bulk density (grams per cubic centimeter) of the material to be tested rounded out within a reasonable tolerance. If the actual bulk density of a certain material is not known, the typical density factor for the most nearly similar material listed in Table 5 may be used.

To perform the actual sieve analysis, sieves should be chosen in a sequence as described earlier. Use every sieve, every other sieve, or every third sieve, etc. between the desired size parameters. The use of sieves in this sequential order will allow for better data presentation and a more meaningful analysis of the test results. Care should also be taken in selecting the proper sieves to avoid overloading any sieve with an especially large material peak. For example, a specification may require 96% of the sample be retained above a #50 mesh sieve. The proper way to perform an analysis of this nature is to use 'relief screen', that is, sieves in the 30, 35, 40 and 45 mesh ranges to remove some of the burden from the critical cut point of 50 mesh. If the relief sieves are not used, the particles of exactly 50 mesh size or slightly larger may become wedged in or forced through the sieve openings by the mass of material resting above them. Large concentrations of material on one sieve reduce the opportunity for near sized material to pass through the sieve resulting in a larger portion of the material retained on the test sieve. The sieve cut point would be inaccurate and the sample would not meet the specifications for the test.

The selected sieves should be assembled with the coarsest sieve at the top of the stack and the balance of the stack in increasing magnitude of fineness (increasing sieve numbers with smaller openings). The stack should include a cover on the top sieve and a pan below the finest sieve. The sieve stack can be shaken then rapped by hand or mounted in a sieve shaker with a motorized or electrostatic drive mechanism.



While many applications still use the hand-shaken method for sieving, motor driven shakers have proven to be much more consistent, minimizing variations related to operator procedures. In powder analysis below the 100 mesh range, the sieve shaker should be equipped with a device to impart a shock wave to the sieve stack at regular intervals. This hammer or rapping device is necessary to reorient the particles on the sieve and impart some shear forces to near-sized particles blocking the sieve openings.

Recommended Time Intervals

The duration of the sieving interval is usually regulated by industry standards, or by in-house control specifications. Commonly, 10, 15 or 20 minute tests are used as arbitrary sieving intervals. To determine the best interval for a new material, or to double check the accuracy of existing specifications, the following procedure can be used. Select the desired sieves for the analysis. 1) Weigh up a sample of the material to be tested and introduce it to the complete sieve stack. 2) Shake the sieve stack for a period of 5 minutes. 3) Weigh the residue in the pan and calculate the percentage in relation to the starting weight. 4) Reassemble the stack and shake for one additional minute. 5) Repeat the weigh-up procedure and calculate the percentage. If the percentage of fines increased more than 1% between 5 minutes and 6 minutes, reassemble the stack and shake for an additional minute. The data can be plotted as percentage throughput versus time for each data point you calculate. When the change in the percentage of fines passing in the 1 minute period drops below 1%, the

test can be considered complete. Record the total testing time for subsequent analyses.

Another type of sieve analysis is the wet sieve test. In this method, the sample is weighed and then washed through the finest sieve in the stack with water, a wetting agent (water based), or some other compatible solvent. After thoroughly washing the fines from the raw sample, the residue is dried either over a hot plate or in an oven. The temperature of the sieve should be maintained below 149°C (300°F)¹ to avoid loosening of the sieve cloth or failure of the solder joint. After drying, the residue is then sieved normally on the balance of the sieve stack. The loss in weight not accounted for on the coarse screens is assumed to be fines or soluble material.

Wet sieve analysis is especially helpful when working with naturally agglomerated materials, ultra-fine powders with severe static changes and in samples where fine particles tend to cling to the coarse fractions in the blend. The disadvantages associated with wet sieving are primarily the time period required to perform the analysis due to the additional washing and drying time and the possible damage to the sieve mesh by overloading. A common practice with wet sieving operations is brushing or forcing the sample through the mesh while the liquid medium is directed on the sieve. This pressure can distort the sieve openings or tear the mesh at the solder joint through stress. Therefore, this procedure is not recommended. Once the sieving interval is complete, whether dry or wet sieving is used, the residue on each sieve is removed by pouring the residue into a suitable weighing vessel. To remove material wedged in the sieve's openings, the sieve is inverted over a sheet of paper or suitable collector and the underside of the wire cloth brushed **gently** with a nylon paint brush with bristles cut to a 25.4 mm (1") length. The side of the sieve frame may be tapped gently with the handle of the brush to dislodge the particles between brush strokes. At no time should a needle or other sharp object be used to remove the particles lodged in the wire cloth.

Special care should be taken when brushing sieves finer than 80 mesh. Brushing can cause distortions and irregularities in the sieve openings. The procedure is repeated for each sieve in the stack and contents of the pan.

The individual weights retained on the sieves should be added and compared to the starting sample weight. Wide variations or sample losses should be determined immediately. If the finished sample weight varies more than 2% from the initial weight, the analysis and sample should be discarded and the test performed another sample. If the sample weights are acceptable, complete the calculations and report the individual weights retained on each sieve.

Presentation and analysis of the resulting data is frequently made easier by plotting on one of a number of graph formats. The most common graphic presentation is the plotting of the cumulative percentage of material retained on a sieve (plotted on a logarithmic scale) versus percentage (plotted on a linear scale). The resulting curve allows a quick approximation of the sieve size at the fifty-percentile point of accumulation. The curve also shows the smoothness of the distribution by revealing the presence of bimodal blends in the sample. Other plotting techniques include log-log and direct plotting of micron size versus percentage retained.



¹ Advantech metal framed sieves should not exceed 261° F (127° C). Solder will begin to soften at this point.

Care should be exercised in the analyzing the data in relation to the length of time the test was run. If the sample contains a large amount of elongated or near-size particles, the test results can be misleading. The longer the sieving interval, the greater the opportunity for these problem particles to pass through the sieve's openings. Ideally each fraction

should be inspected microscopically after sieving to determine the integrity of the sieve cut point.

Table 6 lists many of the ASTM published standards on sieve analysis procedures for specific materials or industries.

CHAPTER 7

SIEVE CARE AND CLEANING

Test sieves, like any other piece of analytical laboratory equipment, require regular care to maintain their performance standards. Sieves should be kept clean and dry at all times, and stored either in the cardboard carton provided or in a suitable cabinet. The wire cloth must be taut and free from variations in opening size. For this reason, cleaning procedures must be clearly delineated as part of a comprehensive sieving program.

² Test sieves should be cleaned ultrasonically on a regular basis.* For some installations, this may be done at the end of a shift or at the end of a week, but must be done regularly to assure accurate sieving results. The sieves should be immersed in an ultrasonic cleaner filled with a solution of a mild detergent and water. Prior to reuse, ensure that the test sieves are dried thoroughly. Ultrasonic cleaning prevents the buildup of particles trapped in the sieve openings and prolongs the useful life of the sieve. Between test clean-up, brushing of the mesh, sizes 100 and coarser, is recommended. For best results, use a nylon bristle paint brush with the bristles cut to a length of approximately 25.4 mm (1"). The sieve openings should be brushed from the **underside only** with a gentle circular

motion. Vigorous brushing will distort the sieve openings and reduce the effective life of the sieve. Particles lodged in the sieve openings should never be removed with a sharp object. These particles should be removed in an ultrasonic cleaner only. Brushing should be avoided on sieves finer than 100 mesh, as the fine wires are more likely to bend, distort or even break. Brushing can often loosen the wire cloth; the finer mesh sizes are most susceptible to this damage.

Similarly, cleaning sieves with a compressed air jet is common, but this can

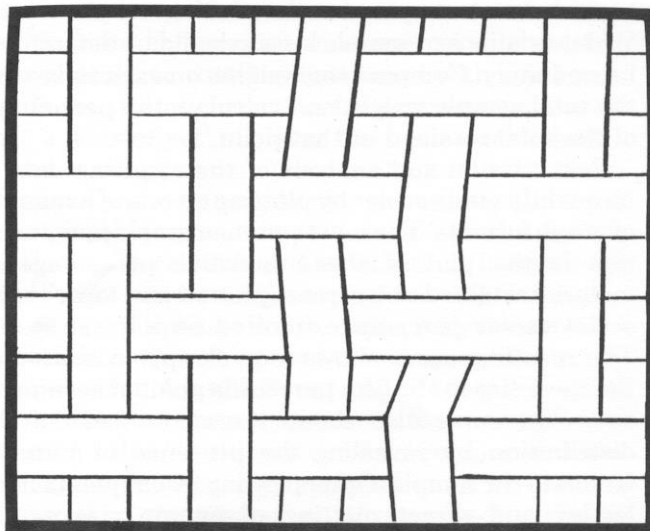

WIRE CLOTH DAMAGED BY IMPROPER BRUSHING

Note the irregularities in both opening size and shape.

² *Do **NOT** ultrasonically clean precision electroformed test sieves. Refer to the Handling and Use Instructions on the sieve jewel case.

damage the sieve openings on the finer mesh sieves. The concentrated jet of air can cause severe 'local' damage to the wire cloth, and significantly reduce the accuracy of the sieve mesh.

With proper care, sieves will perform accurately for many years. Typical wear does not usually change the opening sizes, but can abrade the 'knuckles' or crimps of the wire. A sieve with noticeable sagging of the cloth should be replaced. Fine mesh sieves that are torn should not be resoldered, as the localized heat of the soldering iron can distort the openings. Epoxies have been used for repairs, but

tend to block a large percentage of the openings reducing the opportunity for particles to pass through the openings in the allotted agitation time. Epoxies may become too brittle for the flexing of the wire cloth and can fracture with use.

Good general laboratory procedures should be observed with testing sieves as with any other piece of test equipment. Testing should be performed with clean, uncontaminated sieves, especially when using a sieve for the first time. With proper care and cleaning coupled with a good calibration procedure, any test sieve should provide many years of consistent service.

EPILOG

We hope that the characterization of testing sieves and their uses presented in this manual will serve as an enhancement to your current particle size analysis program. By maximizing the analytical advantage potential of testing sieves while minimizing and compensating for shortcomings and inaccuracies, the testing sieve can be a viable and precise testing tool. Care, maintenance and proper test procedures are as critical with a testing sieve as they are with other, more sophisticated particle size analyzers.

Compliance with applicable industry, national and international specifications is essential. The intent of these regulating bodies is the formulation of general standards to assure uniformity in testing standards observed by both the buyer and producer. The accepted specification should be the foundation for the in-house testing procedure.

Testing accuracy is highly dependent on the technique of the operators. Interpretation of data should be neither overstated nor understated in terms of importance. The effects of variables must be understood, accepted and factored into final data analysis to avoid these shortcomings.

NOTE: To aid in making this manual as understandable and comprehensive as possible, minor changes in spelling and grammar have been made to some of the quoted references. These changes have not altered the statements made but have aided in clarifying the thoughts of the authors.

BIBLIOGRAPHY

1. Allen, Terence, Particle Size Measurement, Chapman and Hall, New York 1981.
2. Leschonski, Kurt "Sieve Analysis, The Cinderella of Particle Size Analysis Methods?", Powder Technology, Elsevier Sequoiz S.A. , Lausanne, 24 (1979)
3. Heywood, Harold, Proc Particle Size Analysis Conference, Bradford, 1970.
4. Leschonski, Kurt, Ibid.
5. Kaye, Brian, Direct Characterization of Fine Particles, John Wiley and Sons, New York, 1981.
6. Gaudin, A.M. Principles of Mineral Dressing, McGraw-Hill, New York 1939.
7. Manual on Test Sieving Methods-STP 447 A, American Society of Testing and Materials, Philadelphia, 1969.

STANDARD SPECIFICATION FOR WOVEN WIRE TEST SIEVE CLOTH AND TEST SIEVES ASTM E11 - 15

Nominal Dimensions and Permissible Variations for Sieve Cloth and Compliance, Inspection and Calibration Test Sieves

| (1) | (2) | (3) | (4) | (5) | (6) | (13) | (14) | (15) |
|-------------------|-------------|-----------------------------|--------------------------------------|--------------------------------------|--------------------------------------|-----------------------|-----------------------------|-------|
| Sieve Designation | | Nominal Sieve Opening (in.) | ± Y Variation for Average Opening | + X Maximum Variation for Opening | Resulting Maximum Individual Opening | Typical Wire Diameter | Permissible Range of Choice | |
| Standard | Alternative | | | | | | Min | Max |
| millimeter | | inches | millimeter | millimeter | millimeter | millimeter | | |
| 125 | 5 in. | 5 | 3.66 | 4.51 | 129.51 | 8 | 6.8 | 9.2 |
| 106 | 4.24 in. | 4.24 | 3.12 | 3.99 | 109.99 | 6.3 | 5.4 | 7.2 |
| 100 | 4 in. | 4 | 2.94 | 3.82 | 103.82 | 6.3 | 5.4 | 7.2 |
| 90 | 3 1/2 in. | 3.5 | 2.65 | 3.53 | 93.53 | 6.3 | 5.4 | 7.2 |
| 75 | 3 in. | 3 | 2.22 | 3.09 | 78.09 | 6.3 | 5.4 | 7.2 |
| 63 | 2 1/2 in. | 2.5 | 1.87 | 2.71 | 65.71 | 5.6 | 4.8 | 6.4 |
| 53 | 2.12 in. | 2.12 | 1.58 | 2.39 | 55.39 | 5 | 4.3 | 5.8 |
| 50 | 2 in. | 2 | 1.49 | 2.29 | 52.29 | 5 | 4.3 | 5.8 |
| 45 | 1 3/4 in. | 1.75 | 1.35 | 2.12 | 47.12 | 4.5 | 3.8 | 5.2 |
| 37.5 | 1 1/2 in. | 1.5 | 1.13 | 1.85 | 39.35 | 4.5 | 3.8 | 5.2 |
| 31.5 | 1 1/4 in. | 1.25 | 0.95 | 1.63 | 33.13 | 4 | 3.4 | 4.6 |
| 26.5 | 1.06 in. | 1.06 | 0.802 | 1.44 | 27.94 | 3.55 | 3 | 4.1 |
| 25 | 1.00 in. | 1 | 0.758 | 1.38 | 26.38 | 3.55 | 3 | 4.1 |
| 22.4 | 7/8 in. | 0.875 | 0.681 | 1.27 | 23.67 | 3.55 | 3 | 4.1 |
| 19 | 3/4 in. | 0.750 | 0.579 | 1.13 | 20.13 | 3.15 | 2.7 | 3.5 |
| 16 | 5/8 in. | 0.625 | 0.490 | 0.99 | 16.99 | 3.15 | 2.7 | 3.6 |
| 13.2 | 0.530 in. | 0.530 | 0.406 | 0.86 | 14.06 | 2.8 | 2.4 | 3.2 |
| 12.5 | 1/2 in. | 0.500 | 0.385 | 0.83 | 13.33 | 2.5 | 2.1 | 2.9 |
| 11.2 | 7/16 in. | 0.438 | 0.346 | 0.77 | 11.97 | 2.5 | 2.1 | 2.9 |
| 9.5 | 3/8 in. | 0.375 | 0.295 | 0.68 | 10.18 | 2.24 | 1.9 | 2.6 |
| 8 | 5/16 in. | 0.312 | 0.249 | 0.60 | 8.60 | 2 | 1.7 | 2.3 |
| 6.7 | 0.265 in. | 0.265 | 0.210 | 0.53 | 7.23 | 1.8 | 1.5 | 2.1 |
| 6.3 | 1/4 in. | 0.250 | 0.197 | 0.51 | 6.81 | 1.8 | 1.5 | 2.1 |
| 5.6 | No. 3 1/2 | 0.223 | 0.176 | 0.47 | 6.07 | 1.6 | 1.3 | 1.9 |
| 4.75 | No. 4 | 0.187 | 0.150 | 0.41 | 5.16 | 1.6 | 1.3 | 1.9 |
| 4 | No. 5 | 0.157 | 0.127 | 0.37 | 4.37 | 1.4 | 1.2 | 1.7 |
| 3.35 | No. 6 | 0.132 | 0.107 | 0.32 | 3.67 | 1.25 | 1.06 | 1.5 |
| 2.8 | No. 7 | 0.110 | 0.090 | 0.29 | 3.09 | 1.12 | 0.95 | 1.3 |
| 2.36 | No. 8 | 0.0937 | 0.076 | 0.25 | 2.61 | 1 | 0.85 | 1.15 |
| 2 | No. 10 | 0.0787 | 0.065 | 0.23 | 2.23 | 0.9 | 0.77 | 1.04 |
| 1.7 | No. 12 | 0.0661 | 0.056 | 0.20 | 1.90 | 0.8 | 0.68 | 0.92 |
| 1.4 | No. 14 | 0.0555 | 0.046 | 0.18 | 1.58 | 0.71 | 0.6 | 0.82 |
| 1.18 | No. 16 | 0.0469 | 0.040 | 0.16 | 1.34 | 0.63 | 0.54 | 0.72 |
| 1 | No. 18 | 0.0394 | 0.034 | 0.14 | 1.14 | 0.56 | 0.48 | 0.64 |
| micrometer | | inches | micrometer | micrometer | micrometer | millimeter | | |
| 850 | No. 20 | 0.0331 | 29.1 | 127 | 977 | 0.5 | 0.43 | 0.58 |
| 710 | No. 25 | 0.0278 | 24.7 | 112 | 822 | 0.45 | 0.38 | 0.52 |
| 600 | No. 30 | 0.0234 | 21.2 | 101 | 701 | 0.4 | 0.34 | 0.46 |
| 500 | No. 35 | 0.0197 | 18.0 | 89 | 589 | 0.315 | 0.27 | 0.36 |
| 425 | No. 40 | 0.0165 | 15.5 | 81 | 506 | 0.28 | 0.24 | 0.32 |
| 355 | No. 45 | 0.0139 | 13.3 | 72 | 427 | 0.224 | 0.19 | 0.26 |
| 300 | No. 50 | 0.0117 | 11.5 | 65 | 365 | 0.2 | 0.17 | 0.23 |
| 250 | No. 60 | 0.0098 | 9.9 | 58 | 308 | 0.16 | 0.13 | 0.19 |
| 212 | No. 70 | 0.0083 | 8.7 | 52 | 264 | 0.14 | 0.12 | 0.17 |
| 180 | No. 80 | 0.0070 | 7.6 | 47 | 227 | 0.125 | 0.106 | 0.15 |
| 150 | No. 100 | 0.0059 | 6.6 | 43 | 193 | 0.1 | 0.085 | 0.115 |
| 125 | No. 120 | 0.0049 | 5.8 | 38 | 163 | 0.09 | 0.077 | 0.104 |
| 106 | No. 140 | 0.0041 | 5.2 | 35 | 141 | 0.071 | 0.06 | 0.082 |
| 90 | No. 170 | 0.0035 | 4.6 | 32 | 122 | 0.063 | 0.054 | 0.072 |
| 75 | No. 200 | 0.0029 | 4.1 | 29 | 104 | 0.05 | 0.043 | 0.058 |
| 63 | No. 230 | 0.0025 | 3.7 | 26 | 89 | 0.045 | 0.038 | 0.052 |
| 53 | No. 270 | 0.0021 | 3.4 | 24 | 77 | 0.036 | 0.031 | 0.041 |
| 45 | No. 325 | 0.0017 | 3.1 | 22 | 67 | 0.032 | 0.027 | 0.037 |
| 38 | No. 400 | 0.0015 | 2.9 | 20 | 58 | 0.03 | 0.024 | 0.035 |
| 32 | No. 450 | 0.0012 | 2.7 | 18 | 50 | 0.028 | 0.023 | 0.033 |
| 25 | No. 500 | 0.0010 | 2.5 | 16 | 41 | 0.025 | 0.021 | 0.029 |
| 20 | No. 635 | 0.0008 | 2.3 | 15 | 35 | 0.02 | 0.017 | 0.023 |

Column 3 - These numbers are only approximate but are in use for reference; the sieve shall be identified by the standard designation in millimeters or micrometers.

Table 1

**INTERNATIONAL STANDARDS ORGANIZATION (ISO)
PREFERRED NUMBER SERIES**

Values in millimeters unless specified as micron (μ).

| R 20/3 | R 20 | * R 40/3 | Equivalent in inches | R 20/3 | R 20 | * R 40/3 | Equivalent in inches |
|--------|------|----------|----------------------|-------------|-----------|-----------|----------------------|
| | 125 | 125 | 4.921 | | | 1.7 | 0.0669 |
| | 112 | | 4.409 | | 1.6 | | 0.0630 |
| | | 106 | 4.173 | 1.4 | 1.4 | 1.4 | 0.0551 |
| | 100 | | 3.937 | | 1.25 | | 0.0492 |
| 90 | 90 | 90 | 3.543 | | | 1.18 | 0.0465 |
| | 80 | | 3.150 | | 1.12 | | 0.0441 |
| | | 75 | 2.953 | 1 | 1 | 1 | 0.0394 |
| | 71 | | 2.795 | | 90 μ | | 0.0354 |
| 63 | 63 | 63 | 2.480 | | | 850 μ | 0.0335 |
| | 56 | | 2.205 | | 800 μ | | 0.0315 |
| | | 53 | 2.087 | 710 μ | 710 μ | 710 μ | 0.0280 |
| | 50 | | 1.969 | | 630 μ | | 0.0248 |
| 45 | 45 | 45 | 1.772 | | | 600 μ | 0.0236 |
| | 40 | | 1.575 | | 560 μ | | 0.0220 |
| | | 37.5 | 1.476 | 500 μ | 500 μ | 500 μ | 0.0197 |
| | 35.5 | | 1.398 | | 450 μ | | 0.0177 |
| 31.5 | 31.5 | 31.5 | 1.240 | | | 425 μ | 0.0167 |
| | 28 | | 1.102 | | 400 μ | | 0.0157 |
| | | 26.5 | 1.043 | 355 μ | 355 μ | 355 μ | 0.0140 |
| | 25 | | 0.984 | | 315 μ | | 0.0124 |
| 22.4 | 22.4 | 22.4 | 0.882 | | | 300 μ | 0.0118 |
| | 20 | | 0.787 | | 280 μ | | 0.0110 |
| | | 19 | 0.748 | 250 μ | 250 μ | 250 μ | 0.0098 |
| | 18 | | 0.709 | | 224 μ | | 0.0088 |
| 16 | 16 | 16 | 0.630 | | | 212 μ | 0.0083 |
| | 14 | | 0.551 | | 200 μ | | 0.0079 |
| | | 13.2 | 0.520 | 180 μ | 180 μ | 180 μ | 0.0071 |
| | 12.5 | | 0.492 | | 160 μ | | 0.0063 |
| 11.2 | 11.2 | 11.2 | 0.441 | | | 150 μ | 0.0059 |
| | 10 | | 0.394 | | 140 μ | | 0.0055 |
| | | 9.5 | 0.374 | 125 μ | 125 μ | 125 μ | 0.0049 |
| | 9 | | 0.354 | | 112 μ | | 0.0044 |
| 8 | 8 | 8 | 0.315 | | | 106 μ | 0.0042 |
| | 7.1 | | 0.280 | | 100 μ | | 0.0039 |
| | | 6.7 | 0.264 | 90 μ | 90 μ | 90 μ | 0.0035 |
| | 6.3 | | 0.248 | | 80 μ | | 0.0031 |
| 5.6 | 5.6 | 5.6 | 0.220 | | | 75 μ | 0.0030 |
| | 5 | | 0.197 | | 71 μ | | 0.0028 |
| | | 4.75 | 0.187 | 63 μ | 63 μ | 63 μ | 0.0025 |
| | 4.5 | | 0.177 | | 56 μ | | 0.0022 |
| 4 | 4 | 4 | 0.157 | | | 53 μ | 0.0021 |
| | 3.55 | | 0.140 | | 50 μ | | 0.0020 |
| | | 3.35 | 0.132 | 45 μ | 45 μ | 45 μ | 0.0018 |
| | 3.15 | | 0.124 | | 40 μ | | 0.0016 |
| 2.8 | 2.8 | 2.8 | 0.110 | | | 38 μ | 0.0015 |
| | 2.5 | | 0.098 | R*10 | 36 μ | | 0.0014 |
| | | 2.36 | 0.093 | 32 μ | | | 0.0013 |
| | 2.24 | | 0.088 | 25 μ | | | 0.0010 |
| 2 | 2 | 2 | 0.079 | 20 μ | | | 0.0008 |
| | 1.8 | | 0.071 | | | | |

* Same as ASTM E 11 USA Standard Sieve Series

R*10 = Tenth root of ten ratio

R 20 = Twentieth root of ten

R 20/3 = Every third number of R 20 Series

R 40/3 = Every third number of fortieth root of ten series

Table 2

**COMPARISON TABLE
INTERNATIONAL TEST SIEVE SERIES**

| INTERNATIONAL ISO 3310-1:2000 | AMERICAN ASTM E 11-01 | | BRITISH BS410:2000 | | CANADA CGSB-8.2-M88 | FRANCE AFNOR NFX11-501 | | GERMANY DIN (ISO) 3310-1:2000 | | JAPAN JIS |
|----------------------------------|--------------------------|------------|-----------------------|-------------|------------------------|---------------------------|-------------|----------------------------------|-------------|--------------|
| | Aperture mm | Opening mm | Equiv. inch/No. | Aperture mm | | Equiv. BS Mesh | Aperture mm | Tamis No. | Aperture mm | |
| 125.00 | 125.00 | 5" | 125.00 | | | | | | | |
| 112.00 | | | 112.00 | | | | | | | |
| 106.00 | 106.00 | 4.24" | 106.00 | | | | | | | |
| 100.00 | 100.00 | 4" | 100.00 | | 100.00 | 100.00 | | 100.00 | | |
| 90.00 | 90.00 | 3 1/2" | 90.00 | | 90.00 | 90.00 | | 90.00 | | |
| 80.00 | | | 80.00 | | | | | | | |
| 75.00 | 75.00 | 3" | 75.00 | | | | | | | |
| 71.00 | | | 71.00 | | 71.00 | 71.00 | | 71.00 | | 71.00 |
| 63.00 | 63.00 | 2 1/2" | 63.00 | | 63.00 | 63.00 | | 63.00 | | |
| 56.00 | | | 56.00 | | | | | | | |
| 53.00 | 53.00 | 2.12" | 53.00 | | 53.00 | 53.00 | | 53.00 | | |
| 50.00 | 50.00 | 2" | 50.00 | | 50.00 | 50.00 | | 50.00 | | 50.00 |
| 45.00 | 45.00 | 1 3/4" | 45.00 | | 45.00 | 45.00 | | 45.00 | | |
| 40.00 | | | 40.00 | | | | | | | |
| 37.50 | 37.50 | 1 1/2" | 37.50 | | | | | | | |
| 35.50 | | | 35.50 | | | | | | | |
| 31.50 | 31.50 | 1 1/4" | 31.50 | | 31.50 | 31.50 | | 31.50 | | |
| 28.00 | | | 28.00 | | 28.00 | 28.00 | | 28.00 | | |
| 26.50 | 26.50 | 1.06" | 26.50 | | | | | | | 26.50 |
| 25.00 | 25.00 | 1.00" | 25.00 | | 25.00 | 25.00 | | 25.00 | | |
| 22.40 | 22.40 | 7/8" | 22.40 | | 22.40 | 22.40 | | 22.40 | | 22.40 |
| 20.00 | | | 20.00 | | 20.00 | 20.00 | | 20.00 | | |
| 19.00 | 19.00 | 3/4" | 19.00 | | | | | | | 19.00 |
| 18.00 | | | 18.00 | | | 18.00 | | 18.00 | | |
| 16.00 | 16.00 | 5/8" | 16.00 | | 16.00 | 16.00 | | 16.00 | | 16.00 |
| 14.00 | | | 14.00 | | 14.00 | 14.00 | | 14.00 | | |
| 13.20 | 13.20 | .530" | 13.20 | | | | | | | |
| 12.50 | 12.50 | 1/2" | 12.50 | | 12.50 | 12.50 | | 12.50 | | 12.50 |
| 11.20 | 11.20 | 7/16" | 11.20 | | 11.20 | 11.20 | | 11.20 | | 11.20 |
| 10.00 | | | 10.00 | | 10.00 | 10.00 | | 10.00 | | |
| 9.50 | 9.50 | 3/8" | 9.50 | | | | | | | 9.50 |
| 9.00 | | | 9.00 | | | 9.00 | | 9.00 | | |
| 8.00 | 8.00 | 5/16" | 8.00 | | 8.00 | 8.00 | | 8.00 | | 8.00 |
| 7.10 | | | 7.10 | | 7.10 | 7.10 | | 7.10 | | |
| 6.70 | 6.70 | .265" | 6.70 | | | | | | | 6.70 |
| 6.30 | 6.30 | 1/4" | 6.30 | | 6.30 | 6.30 | | 6.30 | | |
| 5.60 | 5.60 | No.3 1/2 | 5.60 | 3 | 5.60 | 5.60 | | 5.60 | | |
| 5.00 | | | 5.00 | | | | 38 | 5.00 | | 5.00 |
| 4.75 | 4.75 | No.4 | 4.75 | 3 1/2 | | | | | | |
| 4.50 | | | 4.50 | | | 4.50 | | 4.50 | | |
| 4.00 | 4.00 | No.5 | 4.00 | 4 | 4.00 | 4.00 | 37 | 4.00 | 2E | |
| 3.55 | | | 3.55 | 5 | | 3.55 | | 3.55 | | |
| 3.35 | 3.35 | No.6 | 3.35 | | | | | | | |
| 3.15 | | | 3.15 | | 3.15 | 3.15 | 36 | 3.15 | | |
| 2.80 | 2.80 | No.7 | 2.80 | 6 | 2.80 | 2.80 | | 2.80 | | |
| 2.50 | | | 2.50 | | 2.50 | 2.50 | 35.00 | 2.50 | | |
| 2.36 | 2.36 | No.8 | 2.36 | 7 | | | | | | |
| 2.24 | | | 2.24 | | | 2.24 | | 2.24 | | |
| 2.00 | 2.00 | No.10 | 2.00 | 8 | 2.00 | 2.00 | 34 | 2.00 | 3E | |
| 1.80 | | | 1.80 | | | 1.80 | | 1.80 | | |
| 1.70 | 1.70 | No.12 | 1.70 | 10 | | | | | | |
| 1.60 | | | 1.60 | | 1.60 | 1.60 | 33 | 1.60 | | |
| 1.40 | 1.40 | No.14 | 1.40 | 12 | 1.40 | 1.40 | | 1.40 | | 1.40 |
| 1.25 | | | 1.25 | | | 1.25 | 32 | 1.25 | | |
| 1.18 | 1.18 | No.16 | 1.18 | 14 | | | | 1.20 | 5 | |
| 1.12 | | | 1.12 | | 1.12 | 1.12 | | 1.12 | | |
| 1.00 | 1.00 | No.18 | 1.00 | 16 | 1.00 | 1.00 | 31 | 1.00 | 6 | |
| 900µ | | | 900µ | | | 900µ | | 900µ | | |
| 850µ | 850µ | No.20 | 850µ | 18 | | | | | | 850µ |
| 800µ | | | 800µ | | 800µ | 800µ | 30 | 800µ | | |
| 710µ | 710µ | No.25 | 710µ | 22 | 710µ | 710µ | | 710µ | | 710µ |

Table 3 . . .

**COMPARISON TABLE
INTERNATIONAL TEST SIEVE SERIES**

| INTERNATIONAL ISO 3310-1:2000 | AMERICAN ASTM E 11-01 | | BRITISH BS410:2000 | | CANADA CGSB-8.2-M88 | FRANCE AFNOR NFX11-501 | | GERMANY DIN (ISO) 3310-1:2000 | | JAPAN JIS | |
|--|----------------------------------|-----------------|-------------------------------|----------------|--------------------------------|-----------------------------------|-----------|--|-----------------|----------------------|------|
| Aperture mm | Opening mm | Equiv. inch/No. | Aperture mm | Equiv. BS Mesh | Aperture mm | Aperture mm | Tamis No. | Aperture mm | Approx. DIN No. | Aperture mm | |
| 630µ | 600µ | No.30 | 630µ | 25 | 500µ | 630µ | 29 | 630µ | 10 | 600µ | |
| 600µ | | | 600µ | | | 600µ | | | | | |
| 560µ | | | 560µ | | | 560µ | | | | | |
| 500µ | 500µ | No.35 | 500µ | 30 | | 500µ | 28 | 500µ | 12 | 500µ | |
| 450µ | 425µ | No.40 | 450µ | 36 | 400µ | 450µ | 27 | 450µ | 14 | 425µ | |
| 425µ | | | 425µ | | | 430µ | | | | | |
| 400µ | | | 400µ | | | 400µ | | | | | |
| 355µ | 355µ | No.45 | 355µ | 44 | 315µ | 355µ | 26 | 355µ | 16 | 355µ | |
| 315µ | | | 315µ | | | 315µ | | | | | |
| | | | | | | | | | | | |
| 300µ | 300µ | No.50 | 300µ | 52 | 250µ | | 25 | 300µ | 20 | 300µ | |
| 280µ | 250µ | No.60 | 280µ | 60 | | 280µ | | 25 | 280µ | 24 | 250µ |
| 250µ | | | 250µ | | | 250µ | | | | | |
| 224µ | | | 224µ | | 224µ | | | | | | |
| 212µ | 212µ | No.70 | 212µ | 72 | | 224µ | | 224µ | | 212µ | |
| 200µ | 180µ | No.80 | 200µ | 85 | 200µ | 200µ | 24 | 200µ | 30 | 180µ | |
| 180µ | | | 180µ | | 180µ | | | | | | |
| 160µ | | | 160µ | | 160µ | | | | | | |
| 150µ | 150µ | No.100 | 150µ | 100 | 140µ | 150µ | 23 | 150µ | 40 | 150µ | |
| 140µ | | | 140µ | | | 140µ | | | | | |
| | | | | | | | | | | | |
| 125µ | 125µ | No.120 | 125µ | 120 | 125µ | 125µ | 22 | 125µ | 50 | 125µ | |
| 112µ | 106µ | No.140 | 112µ | 150 | 112µ | 112µ | | | | | |
| 106µ | | | 106µ | | 106µ | | | | | | |
| 100µ | | | 100µ | | 100µ | | | | | | |
| 90µ | 90µ | No.170 | 90µ | 170 | 100µ | 100µ | 21 | 100µ | 60 | 106µ | |
| | | | | 90µ | 90µ | 90µ | | | | | |
| | | | | | | | | | | | |
| 80µ | 75µ | No.200 | 80µ | 200 | 71µ | 80µ | 20 | 80µ | 80 | 75µ | |
| 75µ | | | 75µ | | | 75µ | | | | | |
| 71µ | | | 71µ | | | 71µ | | | | | |
| 63µ | 63µ | No.230 | 63µ | 240 | 63µ | 63µ | 19 | 63µ | 110 | 63µ | |
| 56µ | | | 56µ | | 56µ | | | | | | |
| | | | | | | | | | | | |
| 53µ | 53µ | No.270 | 53µ | 300 | 45µ | | 18 | 53µ | 120 | 53µ | |
| 50µ | 45µ | No.325 | 50µ | 350 | | 50µ | | 17 | | | 50µ |
| 45µ | | | 45µ | | | 45µ | | | | | |
| 40µ | | | 40µ | | 40µ | | | | | | |
| 38µ | 38µ | No.400 | 38µ | 400 | | | | 40µ | | 38µ | |
| 36µ | 32µ | No.450 | 36µ | 440 | 36µ | 36µ | | 36µ | 130 | 32µ | |
| 32µ | | | 32µ | | | 32µ | | | | | |
| 25µ | | | 25µ | | | 25µ | | | | | |
| 20µ | 20µ | No.635 | 20µ | | | 20µ | | 20µ | 200 | 20µ | |

Table 3, cont'd.

**RECOMMENDED REPRESENTATIVE
BULK VOLUMES OF TEST SAMPLES
Used in 8" (203mm) Testing Sieves**

| Standard Sieve Designation | | Bulk Volume of Material | |
|----------------------------|-----------|--|--|
| Standard | Alternate | Recommended Volume of Material for Test Sample | Maximum Permitted Volume on Sieve on Completion of Sieving |
| 25.0mm | 1.00" | 1800cm ³ | 900cm ³ |
| 22.4mm | 7/8" | 1600cm ³ | 800cm ³ |
| 19.0mm | 3/4" | 1400cm ³ | 700cm ³ |
| 16.0mm | 5/8" | 1000cm ³ | 500cm ³ |
| 12.5mm | 1/2" | 800cm ³ | 400cm ³ |
| 11.2mm | 7/16" | 800cm ³ | 400cm ³ |
| 9.50mm | 3/8" | 600cm ³ | 300cm ³ |
| 8.00mm | 5/16" | 500cm ³ | 250cm ³ |
| 6.30mm | 1/4" | 400cm ³ | 200cm ³ |
| 5.60mm | No. 3 1/2 | 400cm ³ | 200cm ³ |
| 4.00mm | No. 5 | 350cm ³ | 150cm ³ |
| 2.80mm | No. 7 | 240cm ³ | 120cm ³ |
| 2.00mm | No. 10 | 200cm ³ | 100cm ³ |
| 1.40mm | No. 14 | 160cm ³ | 80cm ³ |
| 1.00mm | No. 18 | 140cm ³ | 70cm ³ |
| 710μ | No. 25 | 120cm ³ | 60cm ³ |
| 500μ | No. 35 | 100cm ³ | 50cm ³ |
| 355μ | No. 45 | 80cm ³ | 40cm ³ |
| 250μ | No. 60 | 70cm ³ | 35cm ³ |
| 180μ | No. 80 | 60cm ³ | 30cm ³ |
| 125μ | No. 120 | 50cm ³ | 25cm ³ |
| 90μ | No. 170 | 40cm ³ | 20cm ³ |
| 63μ | No. 230 | 35cm ³ | 17cm ³ |
| 45μ | No. 325 | 30cm ³ | 15cm ³ |
| 38μ | No. 400 | 25cm ³ | 12cm ³ |

The recommended weight of material for a sieve test sample is calculated by multiplying the bulk volume figure in Column 3 by the particular bulk density in grams per cubic centimeter of the material, rounded out within a tolerance of ±25 percent.

Table 4

BULK DENSITY OF PULVERIZED MATERIALS IN FREELY Poured CONDITION^a

| Material | Average Weight | | Material | Average Weight | | Material | Average Weight | |
|---------------------|-----------------------|-------------------|-------------------------|-----------------------|-------------------|------------------------|-----------------------|-------------------|
| | lbs./ft. ³ | g/cm ³ | | lbs./ft. ³ | g/cm ³ | | lbs./ft. ³ | g/cm ³ |
| Alumina | 44 | 1.23 | Fullers earth | 30 to 40 | 0.48 to 1.04 | Rubber, chopped | 36 | 0.58 |
| Aluminum, calcined | 128 | 2.05 | Garnet | 168 | 2.69 | Rubber, ground | 20 | 0.32 |
| Aluminum oxide | 122 | 1.96 | Glass beads | 76 | 1.22 | Phosphate rock | 75 to 85 | 1.20 to 1.36 |
| Aluminum shot | 96 | 1.54 | Glass, crushed | 66 | 1.06 | Salt, flake | 61 | 0.98 |
| Ammonium nitrate | 48 | 0.77 | Glass cullet | 93 | 1.49 | Salt, rock | 66 | 1.06 |
| Ammonium - sulfate | 61 | 0.98 | Granite, crushed | 95 to 100 | 1.52 to 1.60 | Salt, table | 75 | 1.20 |
| Bauxite ore | 75 to 85 | 1.20 to 1.36 | Gravel | 90 to 100 | 1.44 to 1.60 | Sand | 90 to 100 | 1.44 to 1.60 |
| Bentonite | 50 to 65 | 0.80 to 1.04 | Gypsum, calcined | 58 | 0.93 | Sand, silica | 90 to 100 | 1.44 to 1.60 |
| Bicarbonate of soda | 57 | 0.91 | Gypsum, crushed | 90 to 100 | 1.44 to 1.60 | Sawdust | 18 | 0.29 |
| Borax | 50 to 61 | 0.80 to 0.98 | Iron ore | 120 to 150 | 1.92 to 2.40 | Seacoal | 42 | 0.67 |
| Boric acid | 58 | 0.93 | Kaolin | 160 | 2.56 | Shale | 100 | 1.60 |
| Calcite | 90 | 1.44 to 1.68 | Kyanite | 68 | 1.09 | Shot, metal | 230 | 3.69 |
| Calcium carbide | 75 | 1.20 | Lime, ground | 60 | 0.96 | Silica, flour | 27 | 0.43 |
| Calcium carbonate | 49 | 0.79 | Lime, hydrated | 25 | 0.40 | Silica, gel | 45 | 0.72 |
| Calcium chloride | 64 | 1.03 | Limestone, crushed | 85 to 100 | 1.36 to 1.60 | Soapstone, pulverized | 40 | 0.64 |
| Calcium phosphate | 57 | 0.91 | Limestone, agricultural | 70 | 1.12 | Soda ash, light | 25 to 35 | 0.40 to 0.56 |
| Carbon black | 24 | 0.33 | Magnesite | 106 | 1.70 | Soda ash, heavy | 55 to 65 | 0.88 to 1.04 |
| Cellulose powder | 16 | 0.26 | Magnetite | 155 | 2.49 | Soda, bicarbonate | 57 | 0.91 |
| Cement, portland | 90 to 100 | 1.44 to 1.60 | Manganese ore | 120 to 136 | 1.92 to 2.18 | Sodium nitrate | 78 | 1.25 |
| Cement clinker | 75 to 80 | 1.20 to 1.28 | Marble, crushed | 90 to 95 | 1.44 to 1.52 | Sodium phosphate | 43 | 0.69 |
| Chrome ore | 140 | 2.25 | Metals, powdered | | | Sodium sulfate | 96 | 1.54 |
| Clay | 30 to 75 | 0.48 to 1.20 | Aluminum | 80 | 1.28 | Steel grit | 228 | 3.66 |
| Coal, anthracite | 55 | 0.88 | Copper | 169 | 2.71 | Stone, crushed | 85 to 95 | 1.36 to 1.52 |
| Coal, bituminous | 50 | 0.88 | Copper-lead | 364 | 5.84 | Sugar, granulated | 5 | 0.80 |
| Coke breeze | 25 to 35 | 0.40 | Iron | 243 | 3.90 | Sugar, powdered | 37 | 0.59 |
| Coke, petroleum | 25 to 40 | 0.40 to 0.64 | Nickel | 263 | 4.22 | Sulphur, crushed | 50 to 65 | 0.80 to 1.04 |
| Copper ore | 100 to 150 | 1.60 to 2.40 | Stainless steel | 240 | 3.85 | Talc, powder | 34 | 0.55 |
| Coquina shell | 80 | 1.28 | Tantalum | 300 | 4.80 | Talc, granular | 44 | 0.71 |
| Corn starch | 40 | 0.64 | Mica | 42 | 0.67 | Traprock, crushed | 105 to 110 | 1.68 to 1.76 |
| Diatomaceous earth | 31 | 0.50 | Ore, sintered | 144 | 1.83 | Triple superphosphate, | | |
| Dicalcium phosphate | 64 | 1.03 | Oyster shells, ground | 29 | 0.47 | granular | 64 | 1.03 |
| Dolomite, crushed | 90 to 100 | 1.44 to 1.60 | Perlite ore | 65 to 75 | 1.04 to 1.20 | Tungsten carbide | 550 | 8.82 |
| Feldspar, crushed | 65 to 84 | 1.04 to 1.35 | Plaster, calcined | 64 | 1.03 | Urea prills | 43 | 0.69 |
| Ferrophosphorous | 196 | 3.14 | Polyethylene pellets | 36 | 0.58 | Vermiculite ore | 80 | 1.28 |
| Fire clay | 80 | 1.28 | Polyethylene powder | 18 | 0.29 | Wood chips | 13 | 0.21 |
| Flour, wheat | 24 | 0.38 | Poly vinyl chloride | 30 | 0.48 | Zinc dust | 144 | 2.31 |
| Flour, maize | 37 | 0.59 | Potash | 77 | 1.23 | Zirconium oxide | 200 | 3.22 |
| Fluorspar | 90 to 120 | 1.44 to 1.92 | Potassium carbonate | 79 | 1.27 | Zirconium sand | 162 | 2.60 |
| Fly ash | 49 | 0.79 | Pumice | 40 | 0.64 | | | |

^a - Where a single figure is given, it represents an actual weight of a typical average sample of the material recorded by a research laboratory; therefore, the figure can be expected to vary from sample to sample of the same material.

Table 5

**LIST OF ASTM PUBLISHED STANDARDS ON SIEVE ANALYSIS PROCEDURES
FOR SPECIFIC MATERIAL OR INDUSTRIES**

| Material | ASTM Designation | Title of Standard | Sieve No. or Size Range |
|--------------------|------------------|--|-------------------------|
| Aggregates | C117-95 | Standard Test Method for Materials Finer Than 75- μ m (No.200) Sieve in Mineral Aggregates by Washing | No.200 |
| | C136-01 | Standard Test Method for Sieve Analysis of Fine and Coarse Aggregates | 3½ in. - No.200 |
| | C142-97 | Standard Test Method for Clay Lumps and Friable Particles in Aggregates | 1½ in. - No.20 |
| | C330-00 | Standard Specifications for Lightweight Aggregates for Structural Concrete | 1 in. - No.100 |
| | C331-01 | Standard Specifications for Lightweight Aggregates for Concrete Masonry Units | ¾ in. - No.100 |
| | D4791-99 | Standard Test Method for Flat Particles, Elongated Particles, or Flat and Elongated Particles in Coarse Aggregate | |
| | D5821-01 | Standard Test Method for Determining the Percentage of Fractured Particles in Coarse Aggregate | |
| Asbestos | D2589-88 (1997) | Standard Test Method for McNett Wet Classification of Dual Asbestos Fiber | No.4 - No.325 |
| | D2947-88 (1997) | Standard Test Method for Screen Analysis of Asbestos Fibers | |
| Carbon black | D1508-99 | Standard Test Method for Carbon Black, Pelleted-Fines and Attrition | No.100 |
| | D1511-00 | Standard Test Method for Carbon Black-Pellet Size Distribution | No.10 - No.120 |
| | D1514-00 | Standard Test Method for Carbon Black-Sieve Residue | No.30 - No.325 |
| Cement | C184-94 | Standard Test Method for Fineness of Hydraulic Cement by the 150- μ m (No.100) and 75- μ m (No.200) Sieves | No.100 & No.200 |
| | C430-96 | Standard Test Method for Fineness of Hydraulic Cement by the 45- μ m (No.325) Sieve | No. 325 |
| | C786-96 | Standard Test Method for Fineness of Hydraulic Cement and Raw Materials by the 300- μ m (No.50), 150- μ m (No.100), and 75- μ m (No.200) Sieves by Wet Methods | No.50 - No.200 |
| Ceramic | C325-81 (1997) | Standard Test Method for Wet Sieve Analysis of Ceramic Whiteware Clays | No.100 - No.325 |
| | C371-89 (1999) | Standard Test Method for Wire-Cloth Sieve Analysis of Nonplastic Ceramic Powders | No.70 - No.325 |
| Coal | D197-87 (1994) | Standard Test Method for Sampling and Fineness Test of Pulverized Coal | No.16 - No.200 |
| | D4749-87 (1994) | Standard Test Method for Performing the Sieve Analysis of Coal and Designating Coal Size | 5 in. - No.400 |
| Coatings | D3214-96 | Standard Test Methods for Coating Powders and Their Coatings Used for Electrical Insulation | |
| | D3451-01 | Standard Guide for Testing Coating Powders and Powder Coatings | |
| Coke | D293-93 (1999) | Standard Test Method for the Sieve Analysis of Coke | 4 in. - No.200 |
| | D5709-95 (2000) | Standard Test Method for Sieve Analysis of Petroleum Coke | 3 in. - No.200 |
| Enamel | C285-88 (1999) | Standard Test Methods for Sieve Analysis of Wet-Milled and Dry-Milled Porcelain Enamel | No.40 - No.325 |
| Glass | C429-01 | Method for Sieve Analysis of Raw Materials for Glass Manufacture | No.8 - No.200 |
| | D1214-89 (1994) | Test for Sieve Analysis of Glass Spheres | |
| Magnesium | D2772-90 (1997) | Standard Test Method for Sieve Analysis of Electrical Grade Magnesium Oxide | |
| Metal Bearing ores | E276-98 | Standard Test Method for Particle Size or Screen Analysis at No.4 (4.75-mm) Sieve and Finer for Metal-Bearing Ores and Related Materials | No.4 - No.200 |
| | B214-99 | Test for Sieve Analysis of Metal Powders | No.80 - No.325 |
| Metal Powders | D451-91 (1996) | Standard Test Method for Sieve Analysis of Granular Mineral Surfacing for Asphalt Roofing Products | No.6 - No.100 |
| | D452-91 (1997) | Standard Test Method for Sieve Analysis of Surfacing for Asphalt Products | No.12 - No.200 |
| | D546-99 | Standard Test Method for Sieve Analysis of Mineral Filler for Bituminous Paving Mixtures | |
| Perlite | C549-81 (1995) | Standard Specification for Perlite Loose Fill Insulation | |
| Pigments and paint | D185-84 (1999) | Standard Test Methods for Coarse Particles in Pigments, Pastes and Paints | No.325 |
| | D480-88 (1999) | Standard Test Methods for Sampling and Testing of Flaked Aluminum Powders and Pastes | No.100 - No.325 |
| | D1921-01 | Standard Test Method for Particle Size (Sieve Analysis) of Plastic Materials | down to No.400 |
| Porcelain | C285-88 (1999) | Standard Test Methods for Sieve Analysis of Wet-Milled and Dry-Milled Porcelain Enamel | No.40 - No.325 |
| Refractories | C92-95 (1999) | Tests for Sieve Analysis and Water Content of Refractory Materials | 3 in. - No.200 |
| Resins | D2187-94 (1998) | Standard Test Methods for Physical and Chemical Properties of Particulate Ion-Exchange Resins | No.8 - No.100 |
| Rubber additives | D5461-93 (1998) | Standard Test Method for Rubber Additives-Wet Sieve Analysis of Powdered Rubber Chemicals | |
| Soap | D502-89 (1995) | Standard Test Method for Particle Size of Soaps and Other Detergents | No.12 - No.100 |
| Soda ash | E359-00 | Standard Test Methods for Analysis of Soda Ash (Sodium Carbonate) | |
| Soil | D421-85 (1998) | Standard Practice for Dry Preparation of Soil Samples for Particle-Size Analysis and Determination of Soil Constants | No.4 - No.40 |
| | D422-63 (1998) | Standard Test Method for Particle-Size Analysis of Soils | 3 in. - No.200 |
| | D1140-00 | Standard Test Methods for Amount of Material in Soils Finer Than the No.200 (75- μ m) Sieve | No.40 - No.200 |
| | D2217-85 (1998) | Standard Practice for Wet Preparation of Soil Samples for Particle-Size Analysis and Determination of Soil Constants | No.10 - No.40 |
| Vermiculite | C516-80 (1996) | Standard Specification for Vermiculite Loose Fill Insulation | ¾ in. - No.100 |

Table 6

VariSifter™

Frequently Asked Questions

For specific sieving procedures, please refer to [Test Sieving: Principles and Procedures](#) located in the User's Manual.

- 1. Can I use one sieve and fill the rest of the stack with spacers?**

Yes, a single sieve can be used at a time. Be sure to add spacers at the top of the stack and place the sieve at the bottom. Please note when using precision mesh sieves, only one sieve may be used at a time while performing separations of 30 microns and finer.
- 2. When would I need to activate the Horizontal Tappers?**

While sifting media 45 microns and finer, it may be beneficial to incorporate the Horizontal Tappers. These tappers fire opposite the Vertical Tapper and may aid in elimination of particle agglomeration.
- 3. How do I determine the best amplitude setting for my test?**

Always start the test at zero amplitude. Slowly increase the amplitude until the heaviest particles are rolling on the sieve surface. Media particles should arc no higher than half the height of a standard sieve therefore never touching the sieve above it. When using precision mesh sieves, media particles should arc a maximum of ¼" above the wire mesh surface. **Final test results may be adversely affected by not complying with this rule.**
- 4. How long should I run my test?**

Generally, there are industry or "in-house" standards for sieving durations. For instructions on determining the optimum test time, please refer to the *Recommended Time Intervals* section in *Chapter 6: Performing the Sieve Analysis* in the [Test Sieving: Principles and Procedures](#) manual. Generally, the VariSifter test is complete when media is no longer filtering into the next sieve below. It is recommended to perform three tests for repeatability, noting the frequency, amplitude and test time for the running of future tests.
- 5. The media samples are not staying within the stack assembly. What is happening?**

There are a few possible reasons for the sample escaping the stack assembly:

 1. The stack may have been improperly assembled and inserted.
 2. There may be holes or tears in the fines collector or diaphragm or cracks in the sieve frames.
 3. The amplitude may be improperly set.

Start by examining the sieve stack assembly. Be sure the following steps have been executed:

- Hook Fines Collector to bottom of Fines Collector Holder.
- Assemble your sieve stack with up to six standard sieves or up to three precision mesh sieves. If fewer sieves are used, replace with Spacers.
- Add the Top Cone.
- Add the sample.
- Add the Diaphragm.
- Add the Column Lock and snap the arms down under the rim of the Fines Collector Holder.
- Insert the stack assembly into the test chamber until it hits the stop at the

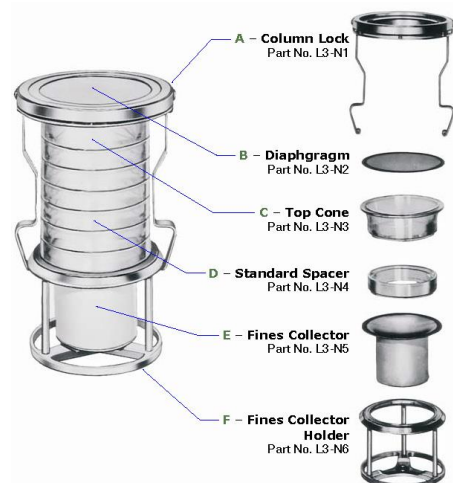

- rear and the table switch is fully engaged.
- Release both arms on the column lock. A firm snapping sound will be heard.
- Your sieve stack should fit **very** securely in the test chamber.
- Place the Column Stop in front of the entire assembly

If this has not solved the problem, visually inspect the Diaphragm and Fines Collector for holes or tears and each sieve frame for cracks. Examine the Column Lock springs. There should be six springs, all oriented vertically.

Lastly, setting the amplitude too high may also contribute to loss of the sample. Refer to **question three** for instructions on setting the amplitude.

- 6. My VariSifter™ does not turn on or will run for a short time, then stop? What is happening?**
The stack assembly must be fully inserted into the test chamber and locked in place by releasing the Column Lock arms. Please refer to **question five** for instructions on properly assembling and inserting the sieve stack assembly. If the column lock is not released, the stack is able to vibrate out of position, releasing the table switch and turning the unit off. The table switch must remain fully engaged in order for the unit to function.
- 7. Can the VariSifter™ be operated with the door open?**
Yes. However, it is not recommended the door be wide open as it may alter your test results.
- 8. Why does the VariSifter™ have a light inside?**
The light allows the user to set the proper amplitude. The sieves were designed with clear acrylic frames so sample media can be viewed while the test is running. The appropriate amplitude has been achieved when the largest particles of the sample are observed rolling on the sieve surface and none arc higher than half the height of the sieve frame. Particles that are arcing too high will be forced back into the sieve above, thereby altering the test results.
- 9. Does the VariSifter™ have to be calibrated?**
No. The VariSifter does not come calibrated. The Frequency setting is a function of internal power converter. Amplitude is an expression of percentage of power.

Test sieves, however, **can** be certified using W.S. Tyler's sieve certification service.
- 10. What regular maintenance does the VariSifter™ require?**
There is no routine maintenance required for the VariSifter™. It is recommended the unit be kept clean by regularly wiping it down with a soft, damp cloth.
- 11. What is the warranty on the VariSifter™?**
The VariSifter™ carries a one-year limited warranty against defective material and workmanship.
- 12. Can I use 3" brass sieves in my VariSifter™?**
No. The VariSifter™ is designed only for use with 3" acrylic sieves and the diaphragm and fines collector. Metal 3" sieves are not compatible.
- 14. Does Advantech/W.S. Tyler have a repair facility nearby?**
Advantech/W.S. Tyler is pleased to offer telephone repair support for the VariSifter, when appropriate. Contact a member of our Tech Support Team at 800-321-6188. Best practice is for machines to be sent in to our location in Mentor, OH for extensive repair or refurbishing. Contact us for information on how to prepare your machine for receipt and service by our Repair Department.

15. My questions have still not been answered.

For further technical support, please contact our Tech Support Team at:

Advantech Manufacturing, Inc. a W.S. Tyler Company

8570 Tyler Blvd, Mentor, OH 44060

T. 800-321-6188 | F. 440-974-0921

E Mail: info@wstyler.com

Web Site: www.wstyler.com

Terms

Driver (X465030): The driver looks like a speaker and produces the sonic vibrations that agitate the particles.

Cam Assembly (X465035): The cam assembly is the spring-loaded pivot block.

Column Lock (L3-N1): Locks the test stack together for easy insertion and removal from the test chamber. Upon release of the arms, helps form a seal between the driver plate and the diaphragm.

Diaphragm (L3N2): Blocks the particles from entering the driver and sits on the top cone. It is made out of latex.

Top Cone (L3-N3): The top cone acts as a funnel and holds the diaphragm on. This is where the sample is introduced into the stack assembly.

Spacers (L3-N4): Spacers are used in place of sieves to maintain the stack assembly height.

Fines Collector (L3-N5): Made of latex, the fines collector collects the minus material that has passed through the stack assembly.

Fines Collector Holder (L3-N6): The fines collector holder is used to hold the fines collector and is the base of the stack assembly.

Stack Assembly (L3-N7): Consists of column lock, diaphragm, fines collector, fines collector holder, top cone and selected sieves or spacers. This device is where the sample is placed for the particle separation.

Column Stop (L3-N9): Placed at the bottom of the test chamber in front of the test stack, this piece ensures the test stack stays in position during testing.

Tapper Coil Assembly (X351404B): Located on the lower portion of the unit, the purpose of the tapper coil assembly is to convert pulsating electrical energy to mechanical energy. It does this at a rate of one vertical tap every four seconds.

Note: The VariSifter™ operates on a sonically agitated air column. The amplitude increases the intensity of sound in the sieve column.

Troubleshooting

| <u>Problem</u> | | <u>Possible Cause</u> |
|--|--|---|
| Unit won't work and is plugged in. | | Check plug input to unit, then check fuse. |
| Unit will sift, but not pulse. | | Pulse timer inoperative. Call for technical support. |
| Unit comes on, but will not sift or pulse. | | Make sure stack assembly is inserted correctly. If the stack assembly is not the problem, the cam assembly may be out of alignment or the trigger spring may be broken. |
| Unit works, but shuts off before timer hits zero. | | Stack assembly has not been unlatched. |
| Unit runs but lacks power. The Column Lock tends to spring open unexpectedly. | | Possible defective driver. The arms on the Column Lock may have fallen out of adjustment. Gently bend the arms toward one another so they get a tighter grip on the Fines Collector Holder. |
